



# VERTUO POP



NESPRESSO

# CLICK AND CHOOSE YOUR LANGUAGE

EN



**SAFETY**



**OVERVIEW**



**CONNECTIVITY**



**FIRST STEPS**



**COFFEE PREPARATION**



**ADAPT YOUR COFFEE VOLUMES**



**CLEANING**



**DESCALING**



**EMPTYING THE SYSTEM**



**RESET TO FACTORY SETTINGS**



**BLINKING SUMMARY**



**TROUBLESHOOTING**



**SPECIFICATIONS**

## SAFETY

**CAUTION:** Before operating your coffee machine, please refer to the [safety instructions leaflet](#) to avoid possible harm and damage.

### DISPOSAL AND ENVIRONMENTAL PROTECTION

This appliance complies with the EU Directive 2012/19/EC. Packaging materials and appliance contain recyclable materials. Your appliance contains valuable materials that can be recovered or can be recycled. Separation of the remaining waste materials into different types facilitates the recycling of valuable raw materials. Leave the appliance at a collection point. You can obtain information on disposal from your local authorities.

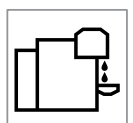

# OVERVIEW

## MACHINE OVERVIEW

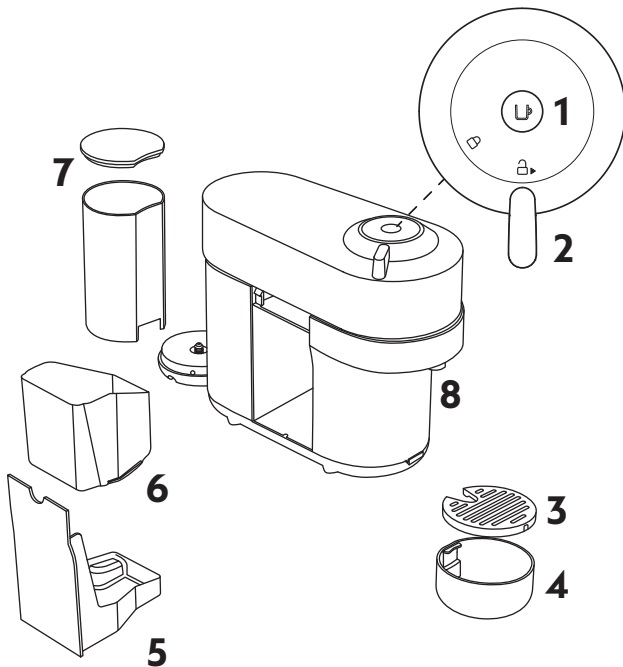

- 1 ON/OFF and Coffee Button
- 2 Locking/Unlocking Lever
- 3 Drip Grid
- 4 Adjustable Cup Support
- 5 Drip Tray
- 6 Container for used Capsules
- 7 Water Tank and Lid
- 8 Coffee Outlet

## PACKAGING CONTENT



- 1 Coffee Machine
- 2 **Nespresso** Capsules Box
- 3 **Nespresso** Welcome Material
- 4 Safety Instructions
- 5 Quick Start Guide
- 6 Warranty

**i Unboxing:** When unpacking the machine, remove the plastic film. Some dust may be present due to recycled materials being used within the packaging. This is not dangerous, simply clean with a soft tissue.

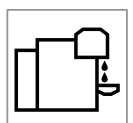



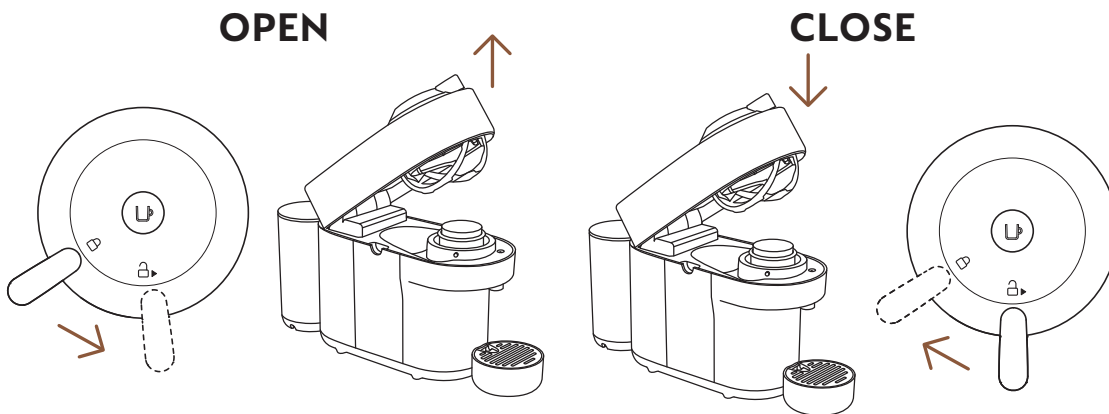

## OPEN / CLOSE



**CAUTION:** for correct machine use, please do not open the machine head while the coffee is brewing, wait until the machine has stopped and the coffee button is steady and white. If you want to stop the brewing earlier, please press the Coffee Button once and wait until the coffee button goes back to steady white.

## THE VERTUO SYSTEM

### CAPSULE COMPATIBILITY

			
<b>S</b>	<b>M</b>	<b>L</b>	<b>XL</b>
<b>Ristretto</b> (25 ml / 0.84 fl oz)	<b>Double Espresso</b> (80 ml / 2.7 fl oz)	<b>Mug</b> (230 ml / 7.77 fl oz)	<b>Alto, Cold Brew Style</b> (355 ml / 12 fl oz)
<b>Espresso</b> (40 ml / 1.35 fl oz)	<b>Gran Lungo</b> (150 ml / 5.07 fl oz)		<b>Carafe</b> (535 ml / 18.8 fl oz)

### ACCESSORY COMPATIBILITY



Discover our full collection of accessories on [www.nespresso.com](http://www.nespresso.com)

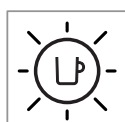
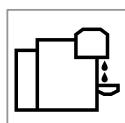
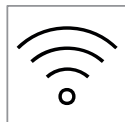

ON/OFF

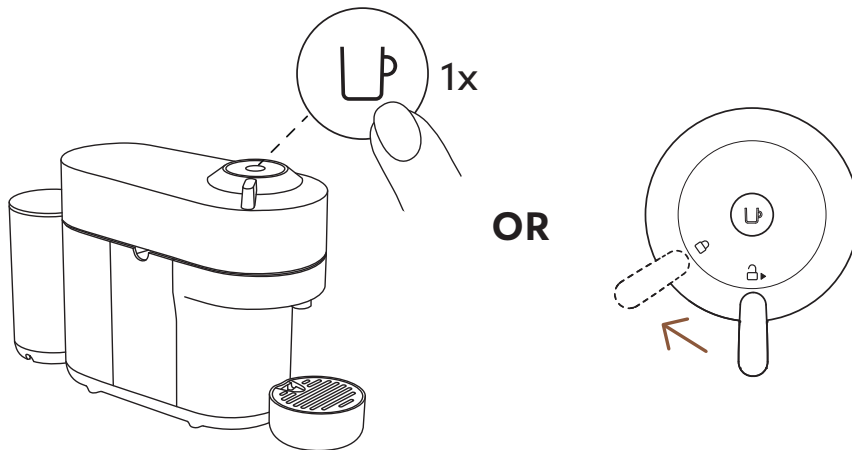

**ON**

Once the machine is plugged in, turn it on by pressing the Coffee Button once or by closing the lever into the lock position (whilst the head is closed).

- i** The light will blink for approximately 30 seconds while the machine is heating up. Once the light is steady, the machine is ready to be used.

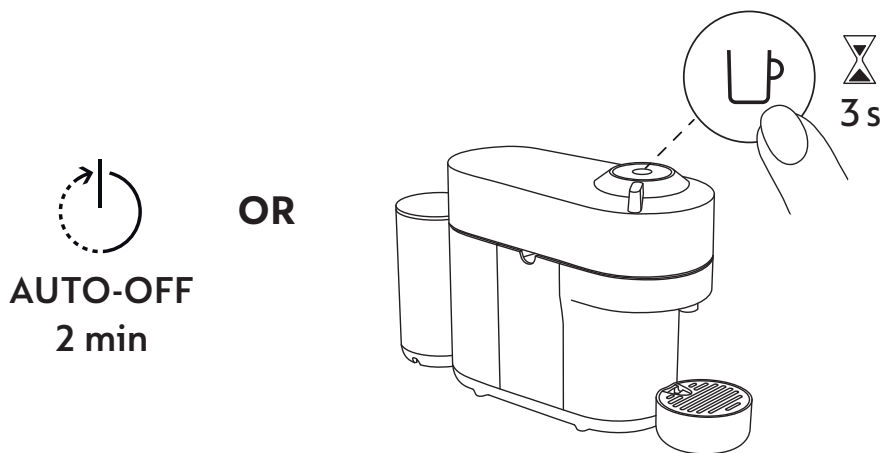

**OFF**

To save energy, the machine will turn off automatically after 2 minutes of non-use.

- i** The machine can be turned “OFF” manually at any time (when not in use) by pressing and holding the Coffee Button for 3 seconds.

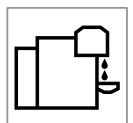
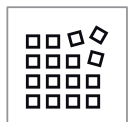

## CONNECTIVITY

### WHY SHOULD YOU PAIR YOUR VERTUO POP MACHINE?

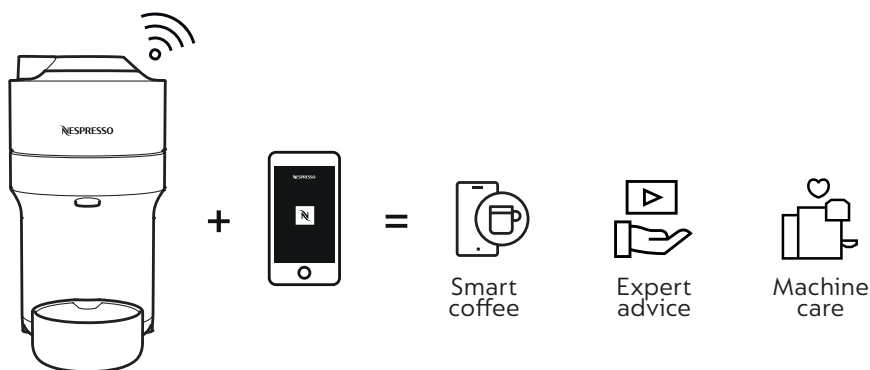

### BENEFITS OF CONNECTING YOUR VERTUO POP MACHINE

- **Smart coffee:** Always stay one step ahead and get the latest coffee innovations from **Nespresso** by keeping your machine up to date
- **Expert advice:** Get support and simple tutorial videos to accompany your coffee journey via your smartphone
- **Machine care:** Receive instant notification on how and when to service your machine with an easy-step guide on descaling, rinsing, cleaning, etc.

### HOW TO CONNECT YOUR VERTUO POP MACHINE?

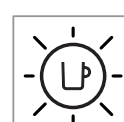
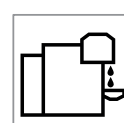
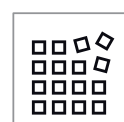

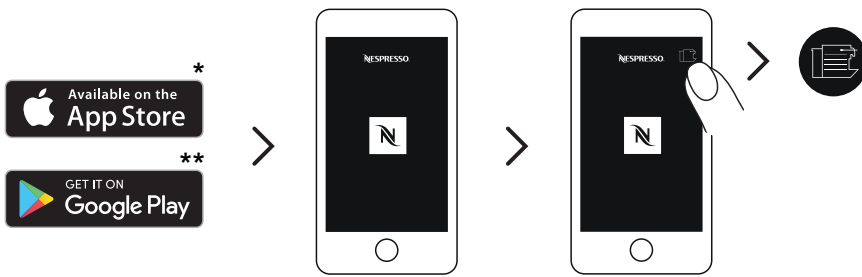

- 1 Download or update the **Nespresso** App. Launch the **Nespresso** App on your smartphone or your tablet. Press the machine icon at the top right of your screen.

**NOTE:** for optimal performance and a seamless experience, we recommend connecting your machine to a Wi-Fi router rather than using a smartphone hotspot.

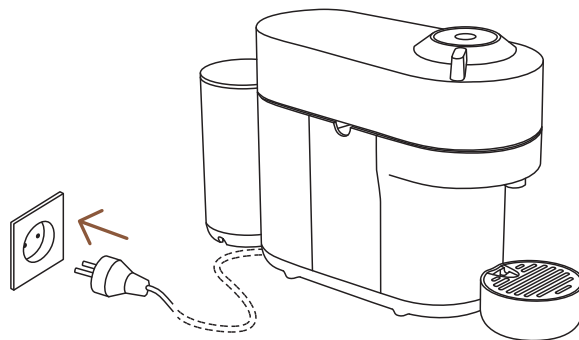

- 2 Plug in the power cord and switch on.



- 3 Follow the instructions via the **Nespresso** App.

**CAUTION:** First read the safety precautions to avoid risks of fatal electrical shock and fire. Please ensure ground continuity when plugging the machine into the power outlet.

- \* AppStore® is a trademark of Apple Inc., registered in the U.S. and other countries.
- \*\* Google Play and the Google Play logo are trademarks of Google LLC.



## DISABLING MACHINE BLUETOOTH AND WI-FI

The machine comes with a connectivity module, enabled by default. It gives access to additional features, enhancing your coffee experience. To disable the connectivity module, follow these steps:

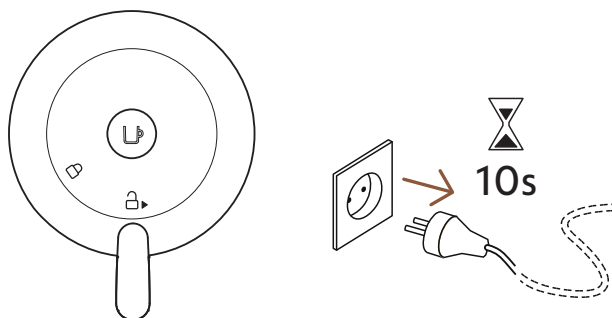

- 1 With the machine closed and the lever in **unlocked** position, unplug the machine for at least 10 seconds.

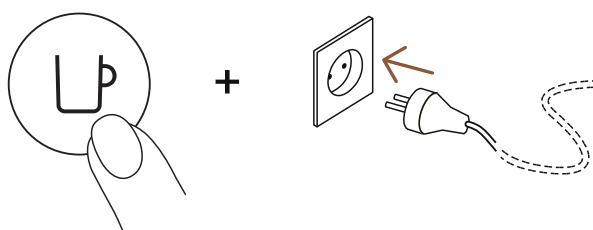

- 2 Press and hold the button whilst plugging in the machine. The button will blink orange to confirm that the connectivity module has now been disabled.

- i** Follow the same steps to set the connectivity module back on again. The button will blink white to confirm that the module has been reactivated.

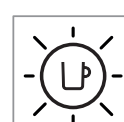
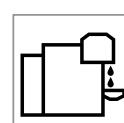
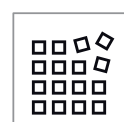

# FIRST STEPS

## FIRST RINSING

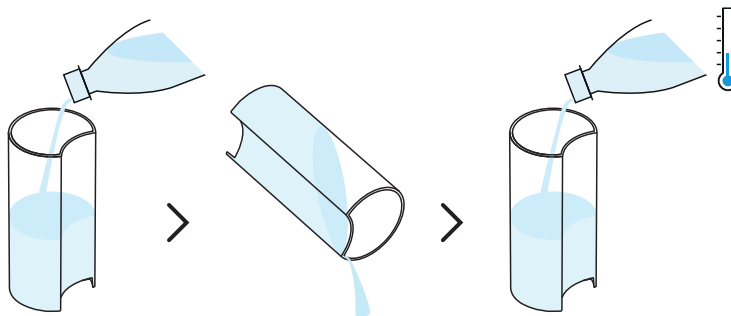

- 1** Rinse and clean the water tank and lid before filling it with fresh drinking water.

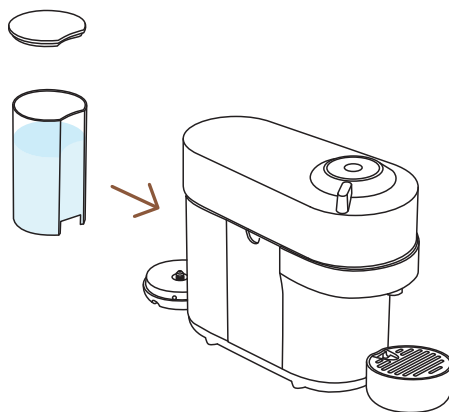

- 2** Put the lid on the water tank and put the water tank in place. Make sure it is properly attached.

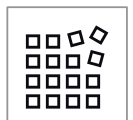

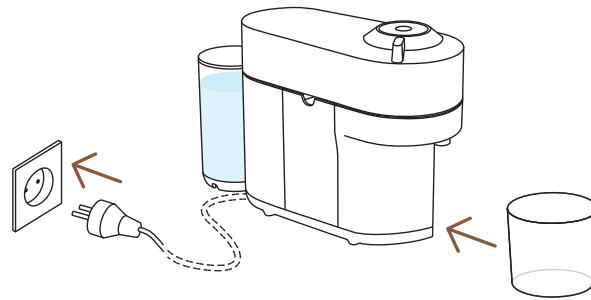

- 3** Plug the power cord in, remove the cup support and place an empty container (of at least 1 L / 34 fl oz) under the coffee outlet.

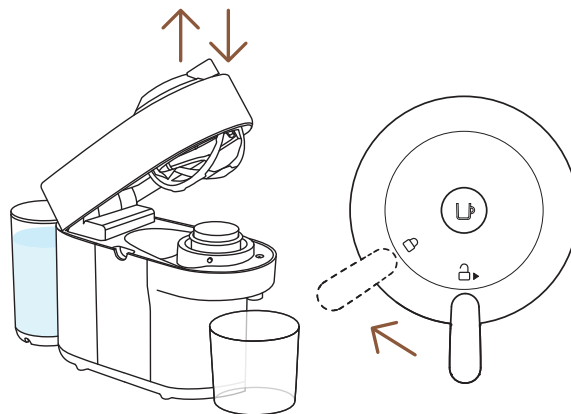

- 4** Open and close the machine. Ensure the lever is in lock position.

- i** The light will blink while the machine is heating up. It will take approximately 30 seconds. When the light becomes steady the machine is ready. Make sure that no capsule is inserted.

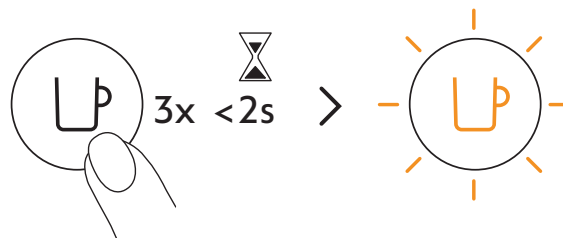

- 5** Press the button 3 times within 2 seconds to start rinsing. Let the rinsing procedure complete automatically. When the light becomes steady white, the cycle is complete.

- i** It should take less than 2 minutes before the rinsing process begins and water starts to flow. This procedure may take up to 7 minutes.

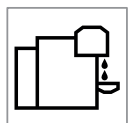

# COFFEE PREPARATION

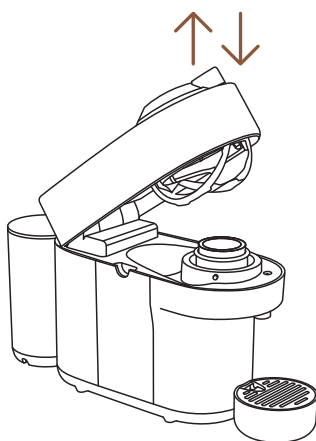

**1** Open and close the machine.

**i** The coffee button light will blink while the machine is heating up. When the light becomes steady, the machine is ready to use.

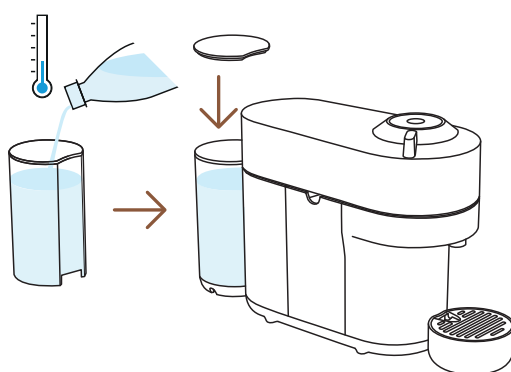

**2** Fill the water tank with fresh drinking water and put it back in position.

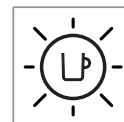
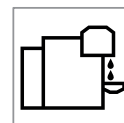
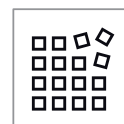
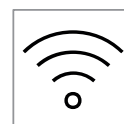

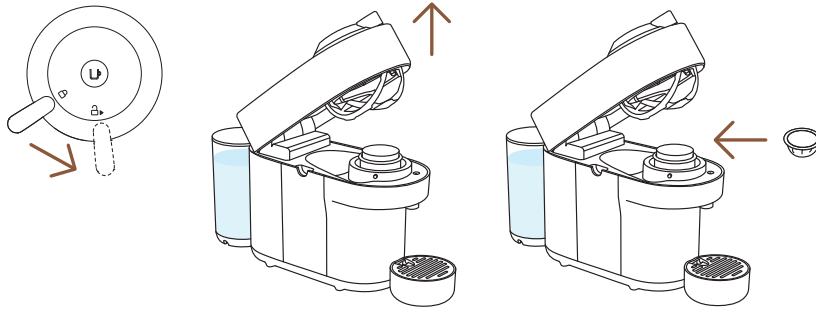

- 3** Unlock and open the machine head completely and insert a Vertuo capsule with the dome shape facing down.

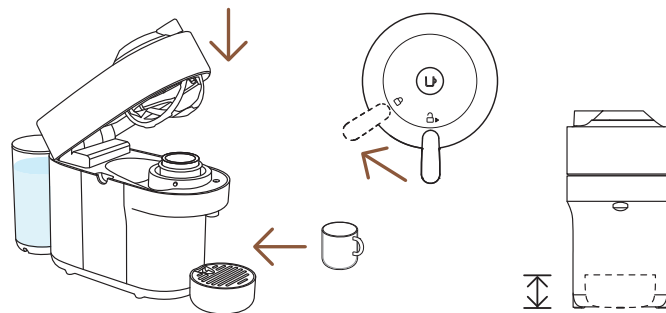

- 4** Close the machine head and lock by turning the lever left into the lock position and place a cup on the cup support. The cup support can be adjusted to accommodate your cup size.

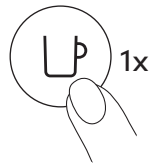

- 5** Start brewing by pressing the button once.

**CAUTION:** for correct machine use, please do not open the machine head while the coffee is brewing, wait until the machine has stopped and the coffee button is steady and white. If you want to stop the brewing earlier, please press the Coffee Button once and wait until the coffee button goes back to steady white.

- i** Due to the barcode reading, coffee pre-wetting and infusion time, it will take a moment before the coffee begins to flow. The machine will automatically recognize the inserted capsule and select the coffee preparation parameters and cup length defined by **Nespresso** coffee experts to extract the coffee blends at it's best.

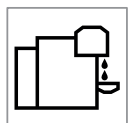

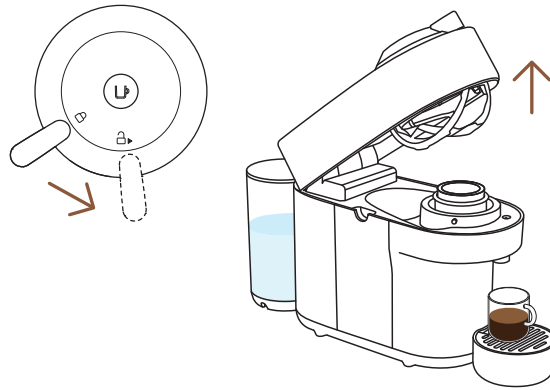

- 6** When the coffee stops brewing, open the machine head by turning the lever right towards the unlock position to automatically eject the capsule and enjoy your coffee.



- 7** Don't forget to recycle your **Nespresso** capsules.\*

\* THIS IS **NESPRESSO**. THIS IS RECYCLABLE. For more information about recycling your **Nespresso** capsules, visit [www.nespresso.com](http://www.nespresso.com)

## DISCOVER OUR COFFEE CREATIONS MODE



With this machine, **Nespresso** offers you a specific function to concentrate your coffee extractions to create your own recipes.

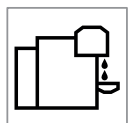
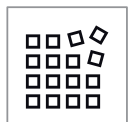

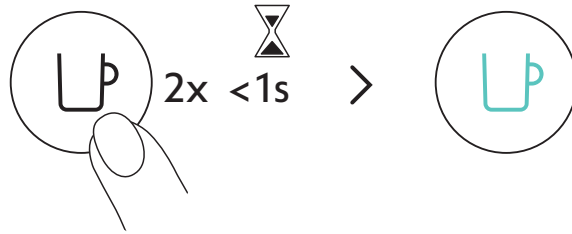

With your machine turned on and a capsule inserted and the head closed and locked, double click the coffee button. It will blink turquoise and your coffee brew will be concentrated, optimizing the coffee taste in recipes with add-ons (milk, cream, over ice...). For Incomparable Coffee Experience.

40 ml / 1.35 fl oz	80 ml / 2.7 fl oz	150 ml / 5.07 fl oz	230 ml / 7.77 fl oz	355 ml / 12 fl oz	535 ml / 18.8 fl oz
✓	✓	✓	✓	✗	✗
25 ml / 0.85 fl oz	40 ml / 1.35 fl oz	40 ml / 1.35 fl oz	80 ml / 2.7 fl oz		

To fully enjoy the benefits, we recommend brewing our Coffee+ range using only the official cup sizes. For the best in-cup results, we do not recommend brewing our XL (Alto Ambrato, Alto Onice), Cold Brew Style & Carafe Pour Over Style with this mode.

**NOTE:** An update of your machine via the **Nespresso** App may be necessary to enable this mode.



Discover how to upgrade your machine with our Aeroccino range on [www.nespresso.com](http://www.nespresso.com)

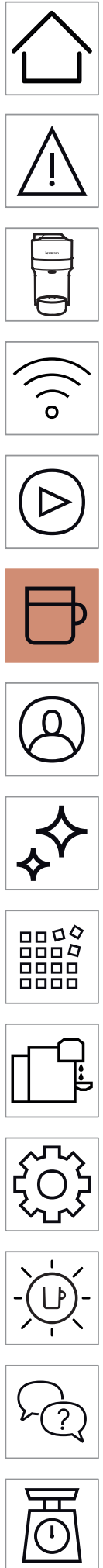

## ADAPT YOUR COFFEE VOLUMES

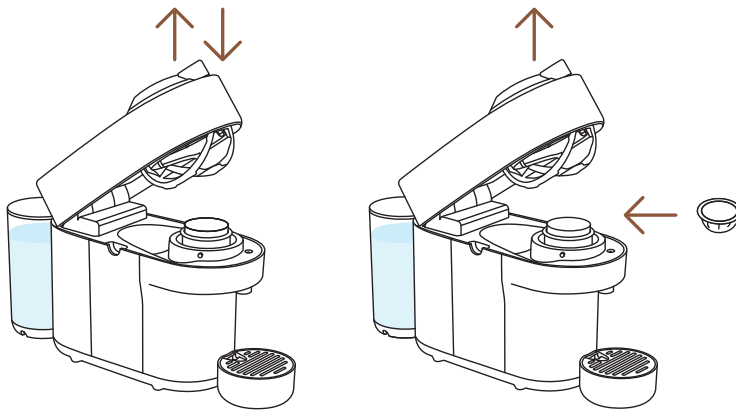

- 1** Open the machine and insert the capsule you want to program.

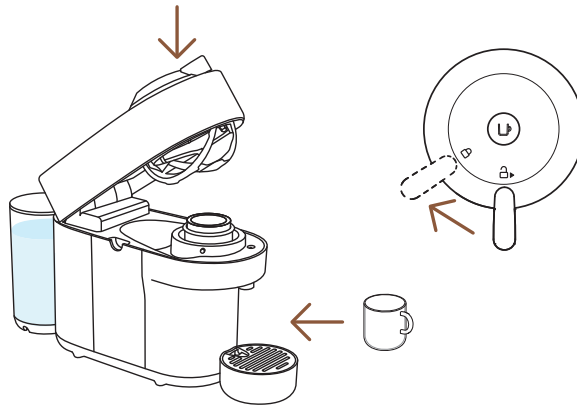

- 2** Close the machine head, turn the lever left towards the lock position and place a cup on the cup support.

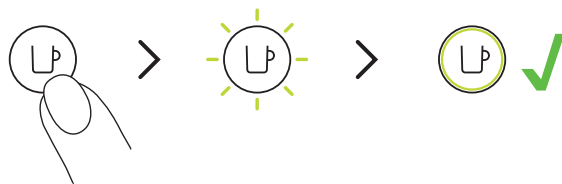

- 3** Press and hold the button, letting go a few seconds before the desired volume is reached. The new water volume is now programmed for the capsule type used during the setting.

- i** The programming is specific to each capsule type. Cup sizes may be programmed from 20 ml / 0.7 fl oz to 535 ml / 18 fl oz.



**CAUTION:** for correct machine use, please do not open the machine head while the coffee is brewing, wait until the machine has stopped and the coffee button is steady and white. If you want to stop the brewing earlier, please press the Coffee Button once and wait until the coffee button goes back to steady white.

**NOTE:** Once a customer-specific volume is programmed by the user, every time that capsule type is inserted in the machine, the preparation will stop at the user-programmed cup size. If you wish to come back to the default parameters see the paragraph “Reset to factory settings”.



## CLEANING

Clean your machine on a monthly basis, when you start having coffee residue inside the machine head or after a long period of non-use.

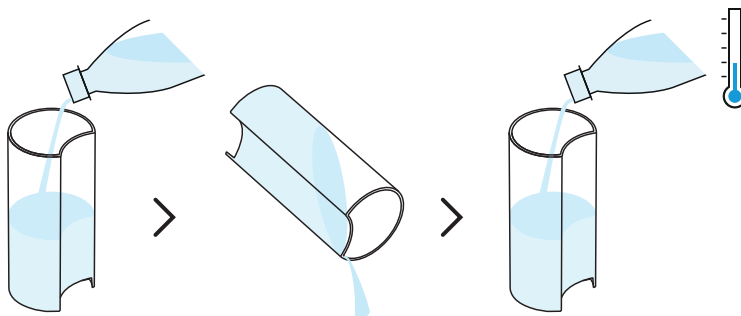

- 1** Rinse and clean the water tank and the lid before filling it with fresh drinking water.

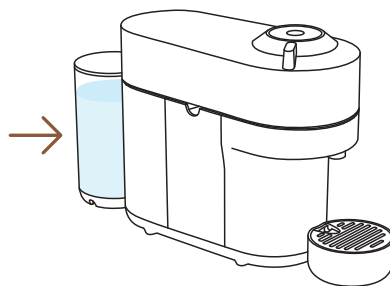

- 2** Put the water tank back in position on the machine.

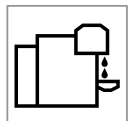
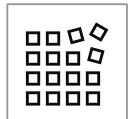

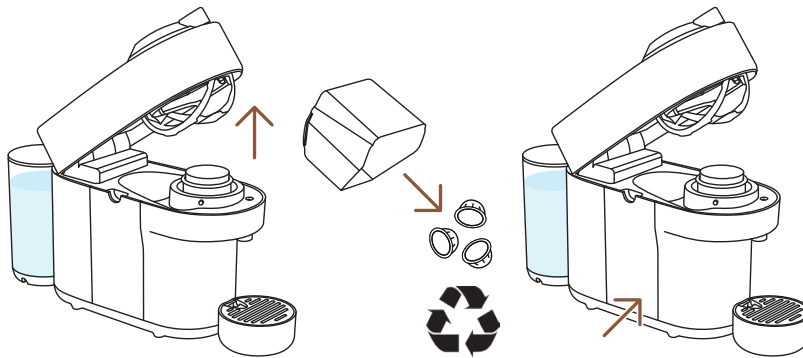

- 3** Unlock and open the machine and eject your used capsule\*. Empty and rinse the capsule container and the drip tray and put them back in place.

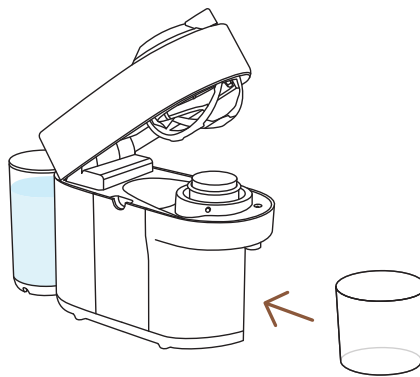

- 4** Remove the cup support and place an empty container (of at least 1 L / 34 fl oz) under the coffee outlet.

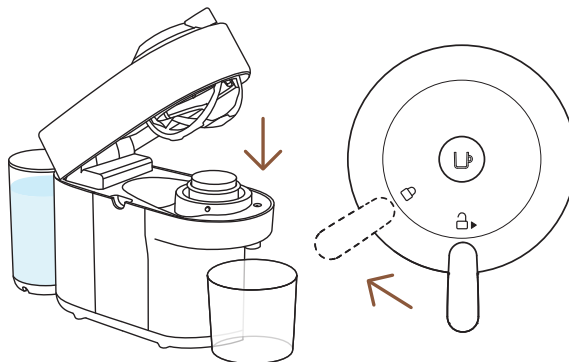

- 5** Close the machine head and turn the lever left towards lock position. Make sure no capsules are present in the machine before starting the cleaning procedure.

\* THIS IS **NESPRESSO**. THIS IS RECYCLABLE. For more information about recycling your **Nespresso** capsules, visit [www.nespresso.com](http://www.nespresso.com)

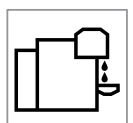

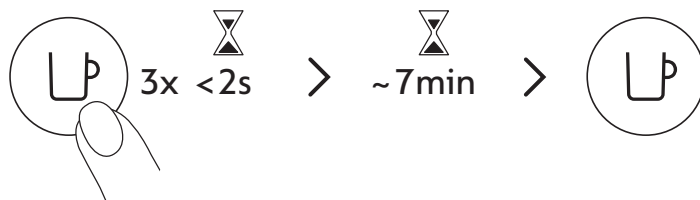

**6** Press the button 3 times within 2 seconds to start rinsing. Let the cleaning procedure complete automatically.

**i** It should take less than 2 minutes before the cleaning process begins and water starts to flow. This operation may take up to 7 minutes and will stop automatically when the cycle is complete. The procedure can be stopped at any time by pressing the button.

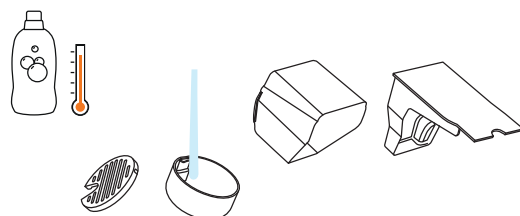

**7** Wash the capsule container, the cup support and the drip tray with hot water and mild odourless detergent.

**CAUTION:** Do not use any strong or abrasive cleaning agent or solvent cleaner. Do not put the machine in a dishwasher. Never immerse the appliance or part of it in water.

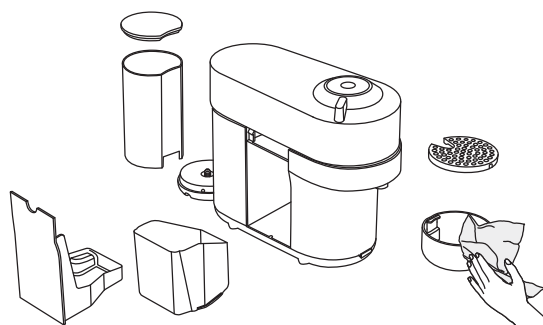

**8** Dry the machine with a clean and fresh towel.

**CAUTION:** Clean the coffee outlet regularly with a clean damp cloth. Always use soft cloths to clean the machine.

**NOTE:** Water may accumulate inside the machine's head during cleaning. If this happens, please dry visible parts with a clean dry cloth.

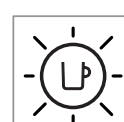
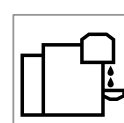
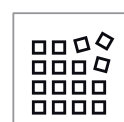
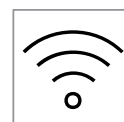

## DESCALING

Descaling your machine will ensure that it functions properly throughout its lifetime and will make your coffee experience as incomparable as it was the first day. Your machine will indicate when descaling is needed by blinking orange 3 times before steady white.



**i** The descaling procedure takes ~20 minutes and **cannot be interrupted**.

**NOTE:** Please carefully read the descaling instructions before starting.

### You will need:

- A descaling kit available on [www.nespresso.com](http://www.nespresso.com)
- An empty container (of 1 L / 34 fl oz)

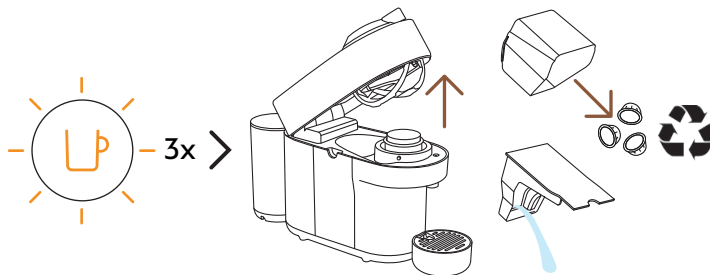

**1** With the button blinking orange 3 times: Unlock and open the machine head to eject any used capsule\*. Empty the capsule container and drip tray and put them back into position on the machine.

\* THIS IS **NESPRESSO**. THIS IS RECYCLABLE. For more information about recycling your **Nespresso** capsules, visit [www.nespresso.com](http://www.nespresso.com)

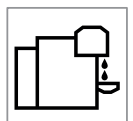
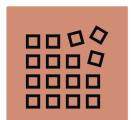

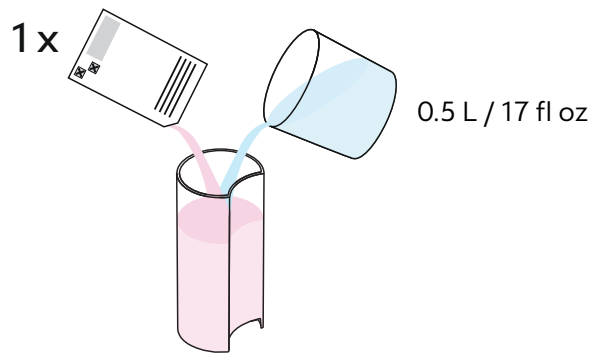

- 2** Fill the water tank with 0.5 L / 17 fl oz of water and add 1 unit of **Nespresso** descaling liquid.

**CAUTION:** Please note that the descaling solution can be harmful. Avoid contact with eyes, skin and surfaces.

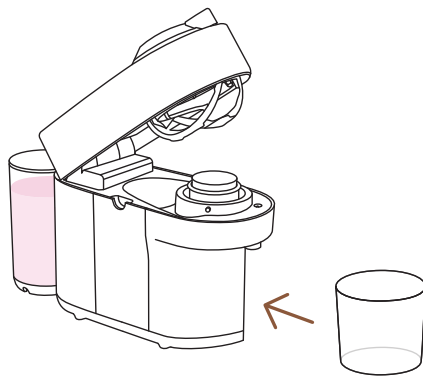

- 3** Remove the cup support and place an empty container (of at least 1 L / fl 34 oz) under the coffee outlet.

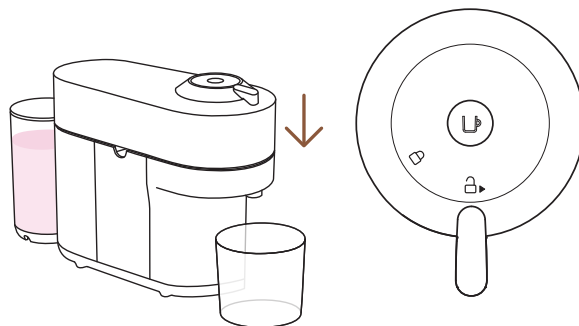

- 4** With the machine on, close the machine head and leave the lever in the unlock position.

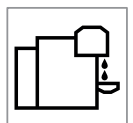
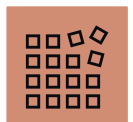

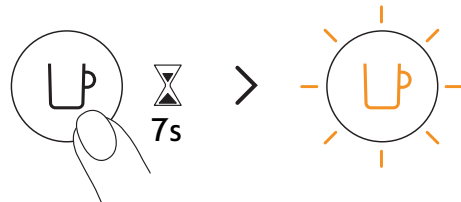

- 5** Hold the button for at least 7 seconds or until you see the light turn off. The button will start blinking orange rapidly.

**CAUTION:** You now have 45 seconds to enter the descaling mode, otherwise the machine will return to the brewing mode.

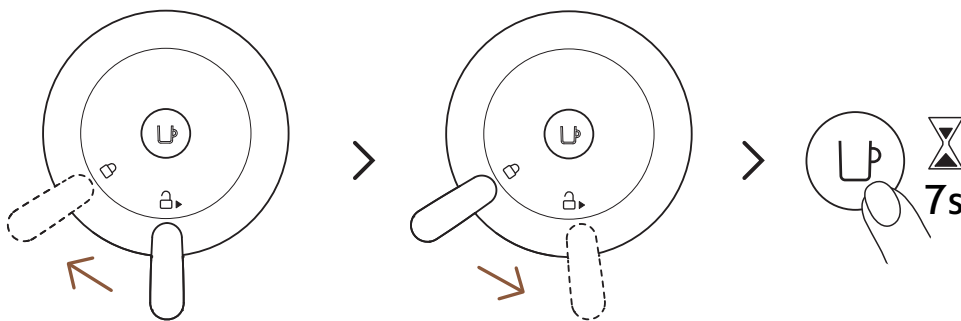

- 6** Lock the machine head by turning the lever left until the lock symbol and then unlock the lever by turning right to the unlock position. Press and hold the button again for approximately 7 seconds or until the light turns off. The button will start blinking orange rapidly.

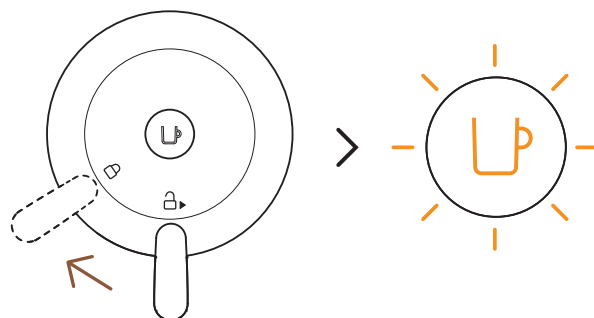

- 7** To enter the descaling mode, lock the machine by turning the lever left towards the lock position. The light should still be blinking orange quickly. This is an indication that you have entered descaling mode.

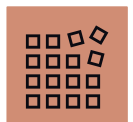

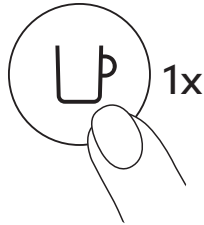

- 8** Press the coffee button once to begin the descaling process. The light will continuously blink orange throughout the process.

- i** The machine will stop automatically when the first phase of descaling is completed.

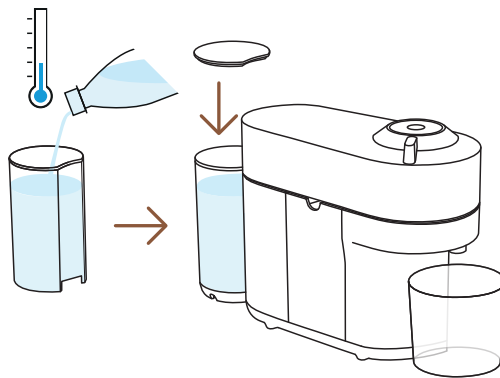

- 9** At the end of the descaling process, it is time to rinse the machine. Rinse the water tank and drip tray thoroughly. Fill the water tank with fresh drinking water and put it back in place. Empty the container and place it back under the coffee outlet.

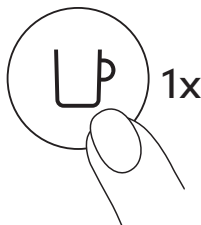

- 10** Press the button to rinse the machine. When the button stops blinking rapidly and becomes steady, the descaling procedure is completed.

- i** The machine will stop automatically when the procedure is completed.

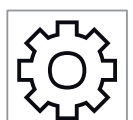
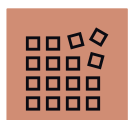

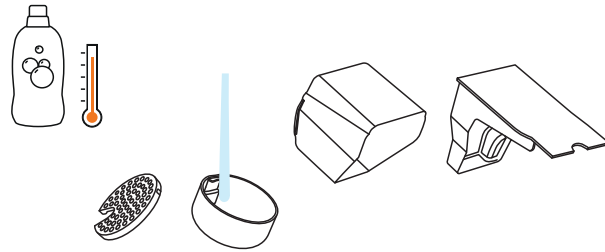

- 11** Wash the capsule container, the cup support and the drip tray with hot water and mild odourless detergent.

**CAUTION:** Do not use any strong or abrasive cleaning agent or solvent cleaner. Do not put the machine in a dishwasher. Never immerse the appliance or part of it in water.

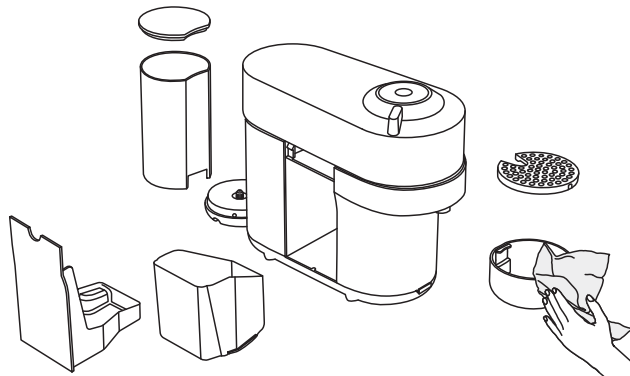

- 12** Dry the machine with a clean and fresh towel. Let the machine dry for 10 minutes before using it.

**NOTE:** Water may accumulate inside the machine's head during cleaning. If this happens, please dry visible parts with a clean dry cloth.

**NOTE:** the machine can only enter descaling mode after 30 or more coffees have been brewed.



## EMPTING THE SYSTEM

Emptying the system is a process that could be done before a period of non-use, for frost protection or prior to sending the machine for a repair.

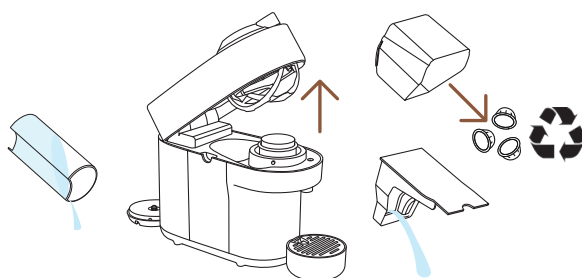

- 1 Empty the water tank, open the machine head, and let the used capsule be ejected. Empty the capsule container and the drip tray. Don't forget to recycle your **Nespresso** capsules.\*

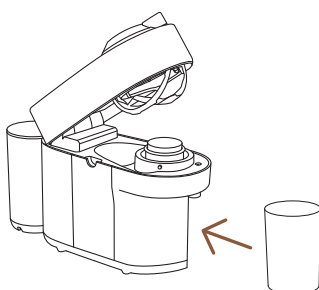

- 2 Place them back in position on the machine, remove the cup support and place an empty container (0.5 L / 17 fl oz) under the coffee outlet.

\* THIS IS **NESPRESSO**. THIS IS RECYCLABLE. For more information about recycling your **Nespresso** capsules, visit [www.nespresso.com](http://www.nespresso.com)

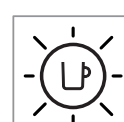
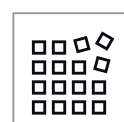
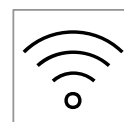

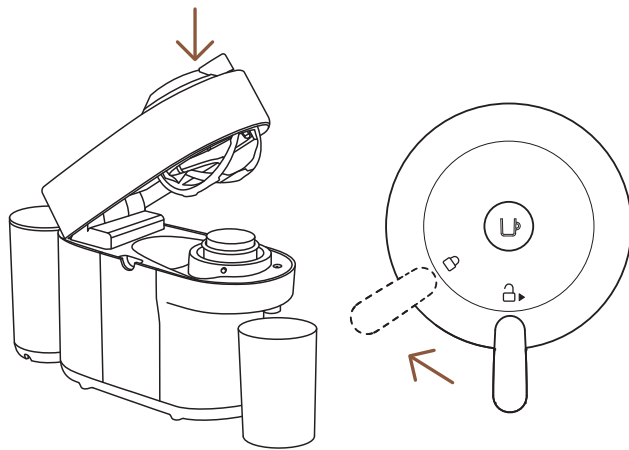

- 3** With the machine plugged in, open and close the machine head and turn the lever towards the lock position.

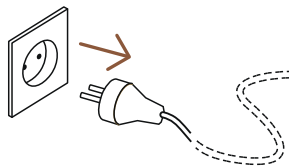

- 4** Unplug the machine.

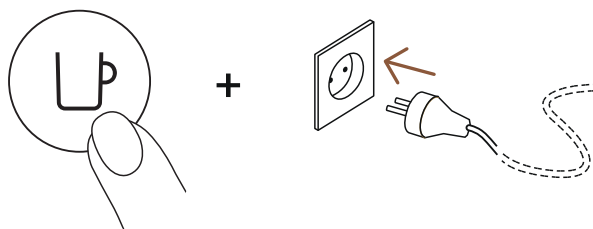

- 5** Press and hold the button while plugging in the machine.

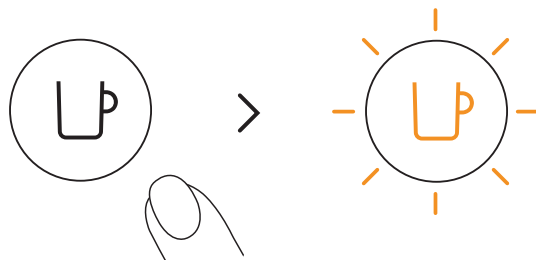

- 6** Release the button. It will blink orange and the emptying process will start.

- i** It will take approximatively 30 seconds for the machine to complete the emptying process. The machine turns off automatically when it is empty.

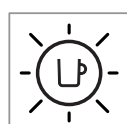
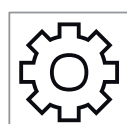
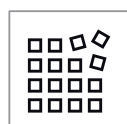
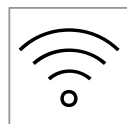

## RESET TO FACTORY SETTINGS

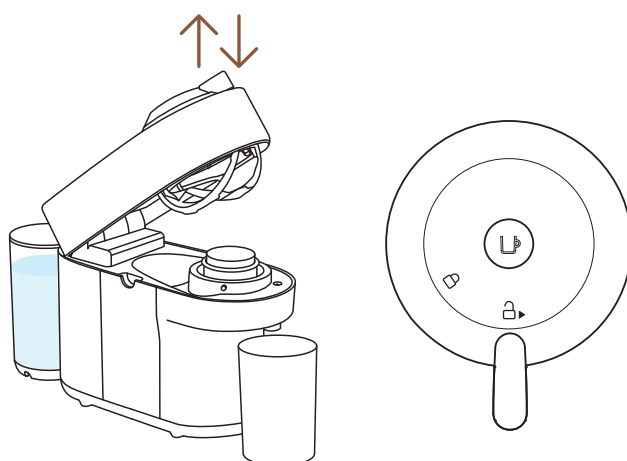

- 1 With the machine plugged in, open and then close the machine head before leaving the lever in the **unlock** position.

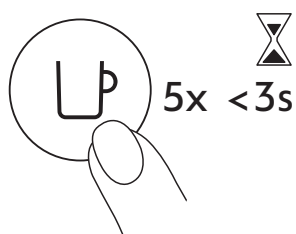

- 2 Press the button 5 times within 3 seconds. The machine is now programmed with the factory settings.

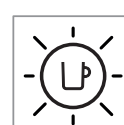
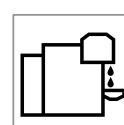
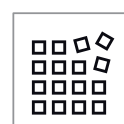
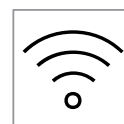

## BLINKING SUMMARY

You want to learn more about the Vertuo Pop blinkings?  
Please watch the following video:

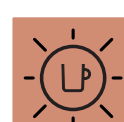
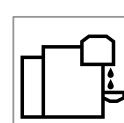
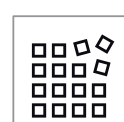
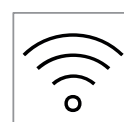

## TROUBLESHOOTING

- No light on the button.**
- The machine has turned OFF automatically; press the button or “UNLOCK” the machine.
  - Check the mains, plug, voltage, and fuse.
- No coffee, no water.**
- Check that the water tank is filled.
  - Check that a fresh capsule is inserted in the correct position, that the lever is properly locked and press the button to start.
  - Descale if necessary.
  - Open the machine head and eject any used capsule that is in the machine. Then perform a clean as per the cleaning section.
- Coffee is not hot enough.**
- Preheat the cup with hot drinking water from the tap.
  - Descale if necessary.
- Leakage or unusual coffee flow.**
- Check that the water tank is well positioned.
  - Descale if necessary.
- Machine turns to “OFF mode”.**
- To save energy the machine will turn off after 2 minutes of non-use.
  - The machine can be turned “OFF” manually at any time (when not in use) by pressing and holding the button for 3 seconds.
- Coffee grounds in the cup.**
- Perform the cleaning procedure twice.
  - See paragraph on **“Cleaning”**.
- The machine doesn't start and has light steady on. If blinking, see next points.**
- Check that the lever is properly locked.
  - If you want to brew a Coffee or Espresso, check that a fresh capsule is inserted in the correct position, that the lever is properly locked and press the button to start.
  - If you are cleaning, descaling or emptying the system, check that no capsule is inserted then close, lock the machine and press the button to start one of these operations.
- The machine doesn't start and light blinks alternately; 1 blink and 1 pause.**
- Fill the water tank and press the button to start.
  - Check that the lever is properly locked.

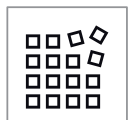

### Light blinks while machine is running.

- If the coffee is flowing normally, this indicates the machine is working properly.
- If only water is flowing, the machine is executing a user request for either cleaning, descaling or emptying the system. Refer to the corresponding section in this user manual.
- Turn the machine to “OFF mode” by pressing the button for 3 seconds and then press it again to turn the machine ON. Now wait approximately 20 minutes to allow the machine to cool down after extensive use.

### Light blinks and machine is not running.

- It will take some time before the coffee flow comes out (due to code reading and pre-wetting the coffee).
- Check that a fresh capsule is inserted in the correct position, that the lever is properly locked and press the button to start.
- Fill the water tank and press the button to start.
- Turn the machine to “OFF mode” by pressing the button for 3 seconds and then press it again to turn the machine ON. Now, wait approximately 20 minutes to allow the machine to cool down after extensive use.

### Light blinks alternately 2 blinks and 1 pause continuously. Machine is not running.

- During regular Coffee/Espresso preparation:
  - 1) Unlock the lever and open the machine head to check that a fresh undamaged capsule is inserted in the correct position.
  - 2) Check that the lever is in “LOCKED” position.
  - 3) Check that the water tank is filled.
- During Descaling, Emptying and Cleaning:
  - 1) Check that the capsule is ejected.
  - 2) Check that the lever is in “LOCKED” position.
- During Programming Volume:
  - 1) Check if a capsule has been well inserted.
  - 2) Please refer to the corresponding chapter **“Adapt your coffee volume”**.

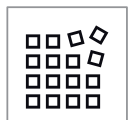

**Light alternately  
blinking 3 times and  
then steady on.**

- If the problem persists:
  - 1) Unlock the lever and open the machine head.
  - 2) Replace the capsule (if needed).
  - 3) Disconnect the power cord from the outlet and plug the machine back into the outlet after 10 seconds.
  - 4) Close the head and press the button to turn ON and press again to start brewing. If the problem persists, call **Nespresso**.
- Descaling needed: the machine can be used only a few times after the descaling alert appears before it becomes necessary.

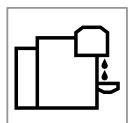

## SPECIFICATIONS

<b>Power</b>	<b>~220–240 V, 50–60 Hz, 1300–1500 W</b> <b>US, CA:</b> 120 V, 60 Hz, 1500 W <b>MX:</b> 127 V~, 60 Hz, 1380 W
<b>Frequency</b>	2.402–2.480 GHz
<b>RF output power (EIRP)</b>	Bluetooth 4 dBm Max. e.i.r.p. and Wi-Fi <20 dMm max. e.i.r.p.
<b>Standby</b>	0.39 W/h
<b>Power saving mode</b>	Auto-off after 2 min
<b>Heat-up time</b>	30 seconds (head closed and locked)
<b>Movable cup support for large recipes</b>	Removable single position
<b>Cable length from device dispatch</b>	75 cm / 30 in
<b>Dimensions (W x D x H)</b>	13.6 x 42.6 x 25 cm / 5.3 x 16.7 x 9.8 in
<b>Weight</b>	3.5 kg / 7.72 lbs
<b>Water tank capacity</b>	600 ml / 20 fl oz
<b>Capsule container capacity</b>	8 espresso or 5 mug capsules

## MACHINE CODES

<b>Nespresso</b>	<b>Breville</b>	<b>Delonghi</b>
GCV2, GDV2	BNV120, BNV150	ENV90
<b>Krups</b>	<b>Magimix</b>	
XN9201, XN9204, XN9205, XN9211	M800	

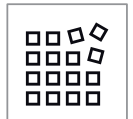

# PAINA VALITAKSESI KIELI

FI



**TURVALLISUUS**



**YLEISKATSAUS**



**YHDISTETTÄVYYS**



**ENSIMMÄINEN KÄYTTÖKERTA**



**KAHVIN VALMISTUS**



**SÄÄDÄ KAHVIN MÄÄRÄÄ**



**PUHDISTAMINEN**



**KALKINPOISTO**



**JÄRJESTELMÄN TYHJENTÄMINEN**



**PALAUTA TEHDASASETUKSET**



**MERKKIVALOJEN YHTEENVETO**



**VIANMÄÄRITYS**



**TEKNISET TIEDOT**

# TURVALLISUUS

**HUOM:** Lue turvallisuusohjeet ennen koneen käyttöä välttyäksesi mahdollisilta vahingoilta.

## HÄVITTÄMINEN JA YMPÄRISTÖNSUOJELU

Tämä laite noudattaa EU-direktiiviä 2012/19/EC.

Pakkausmateriaalit ja laite sisältävät kierrätettäviä materiaaleja.

Laitteesi sisältää arvokkaita materiaaleja, jotka voidaan ottaa talteen tai kierrättää. Jäljelle jääneiden jättemateriaalien lajittelu eri tyypeihin auttaa arvokkaiden raaka-aineiden kierrätystä.

Vie laite keräyspisteeseen. Lisätietoa hävittämisestä saa paikallisviranomaisilta.

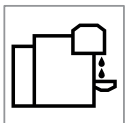
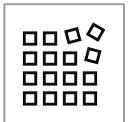

# YLEISKATSAUS

## KONE YLEISESTI

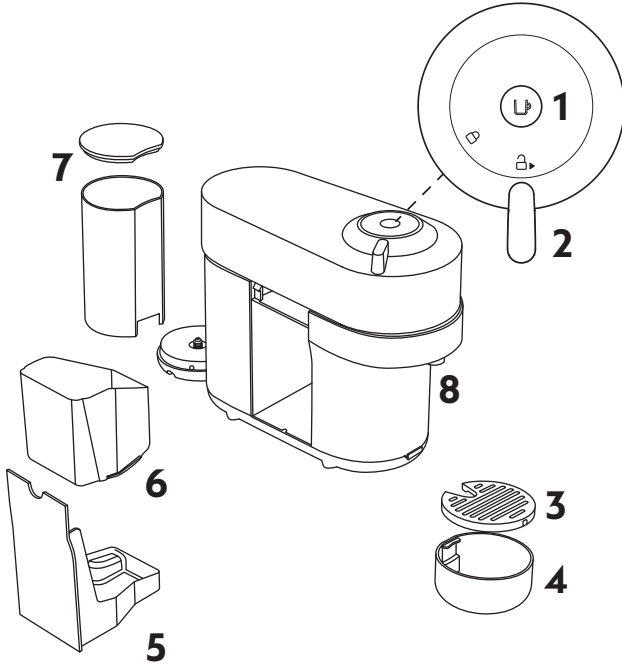

- 1 ON/OFF- ja kahvipainike
- 2 Lukitus- ja avausvipu
- 3 Tipparitilä
- 4 Säädetty kupin tuki
- 5 Tippa-astia
- 6 Käytettyjen kapselien säiliö
- 7 Vesisäiliö ja kansi
- 8 Kahvisuutin

## PAKKAUKSEN SISÄLTÖ



- 1 Kahvikone
- 2 **Nespresso-** kahvikapselivalikoima
- 3 **Nespresson** tervetuliaismateriaali
- 4 Turvallisuusohjeet
- 5 Pikaopas
- 6 Takuu

**i Pakkauksen avaaminen:** laitteen päällä saattaa olla pakkausmateriaalista irronnutta pölyä, johtuen pakkauksessa käytetystä kierrätysmateriaalista. Tämä ei ole haitallista ja voidaan pyyhkiä pois liinalla ennen käyttöä. Poista koneesta löytyvät suojamuovit.

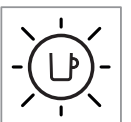
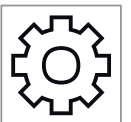
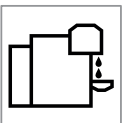
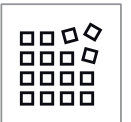



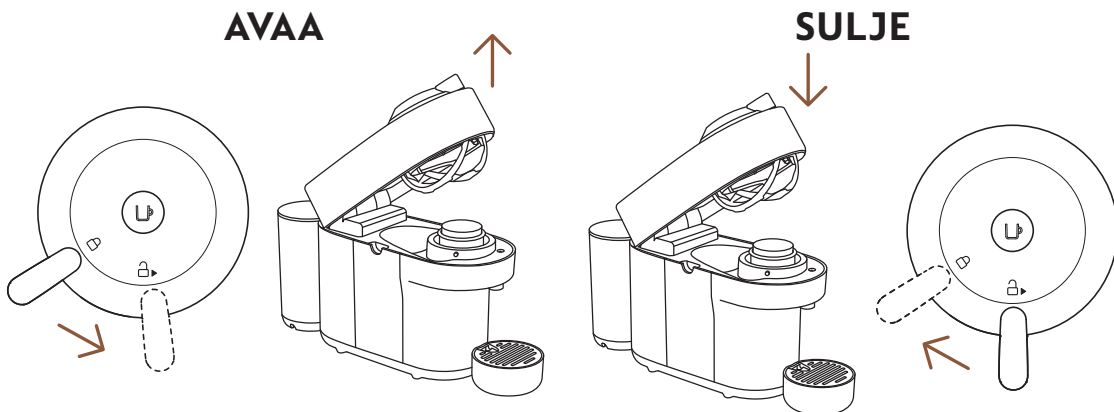

## AVAA/SULJE



**VAROITUS:** koneen oikean käytön varmistamiseksi älä avaa konetta kahvin valmistuksen aikana, vaan odota, kunnes kone on pysähtynyt ja kahvipainike palaa tasaisen valkoisena. Mikäli haluat lopettaa valmistuksen aikaisemmin, paina kahvipainiketta kerran ja odota, kunnes kahvipainike palaa tasaisen valkoisena.

## VERTUO-JÄRJESTELMÄ

### KAPSELEIDEN YHTEENSOPIVUUS

			
<b>S</b>	<b>M</b>	<b>L</b>	<b>XL</b>
<b>Ristretto</b> (25 ml)	<b>Tuplaespresso</b> (80 ml)	<b>Muki</b> (230 ml)	<b>Alto, Cold Brew</b> (355 ml)
<b>Espresso</b> (40 ml)	<b>Gran Lungo</b> (150 ml)		<b>Carafe</b> (535 ml)

### OHEISTUOTTEIDEN YHTEENSOPIVUUS



Tutustu täyteen oheistuotevalikoimaamme osoitteessa  
[www.nespresso.fi](http://www.nespresso.fi)

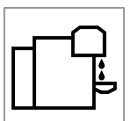
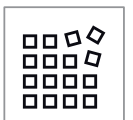
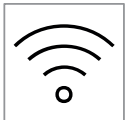

## ON/OFF

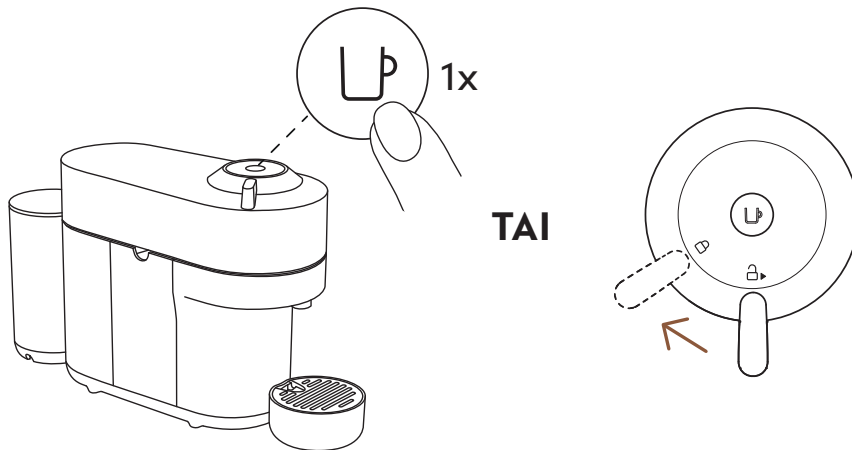
**ON**

Kun kone on kytketty, käynnistä se painamalla painiketta kerran tai sulkemalla vipu lukitsemisasentoon (koneen kansi suljettuna).

- i** Valo vilkkuu noin 30 sekunnin ajan kun kone lämpenee. Kun valo palaa tasaisesti, kone on valmis käytettäväksi.

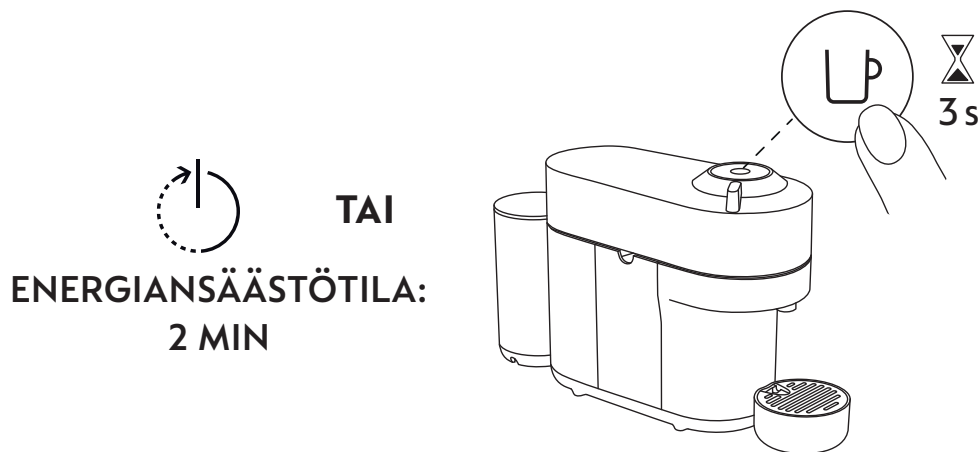
**OFF**

Kahvikoneessa on automaattinen virrankatkaisu kahden minuutin kuluttua edellisen käytön jälkeen.

- i** Kone voidaan kytkeä manuaalisesti pois päältä milloin tahansa (kun ei käytössä) painamalla painiketta yhtäjaksoisesti kolmen sekunnin ajan.

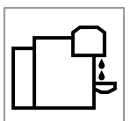

## YHDISTETTÄVYYS

### MIKSI SINUN KANNATTAA YHDISTÄÄ VERTUO POP -KONEESI LAITEPARIKSI\*

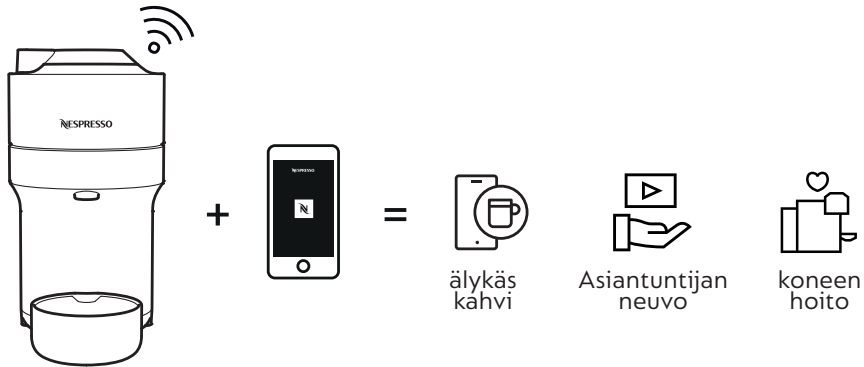

\*Saatavuus vaihtelee maittain

### VERTUO POPIN YHDISTÄMISEN EDUT

- **älykäs kahvi:** Pysy aina ajan tasalla ja saat tietoosi viimeisimmät **Nespresso** kahvi-innovaatiot, pitämällä koneesi hyvässä kunnossa ja päivitetynä
- **Asiantuntijan neuvo:** Saat tukea ja helppoja opetusvideoita kahvimatkaasi varten, älypuhelimesi välityksellä
- **koneen hoito:** Saat välittömiä ilmoituksia ja helppoja ohjeita kahvikoneesi huoltoon, kalkinpoistoon, huuhteluun ja puhdistamiseen liittyen

### KUINKA YHDISTÄN VERTUO POP -KAHVIKONEENI?



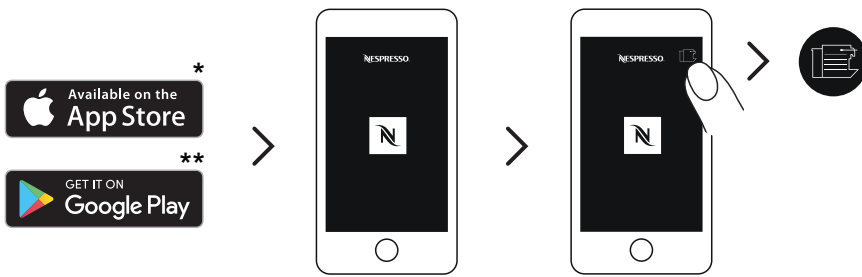

- 1** Lataa tai päivitä **Nespresso**-sovellus. Käynnistä sovellus mobiililaitteellasi. Valitse kahvikoneen kuva näytön oikeasta ylänurkasta.

**HUOMAUTUS:** optimaalisen suorituskyvyn ja saumattoman käyttökokemuksen saavuttamiseksi suosittelemme, että yhdistät laitteesi Wi-Fi-reitittimeen älypuhelimien hotspotin käyttämisen sijaan.

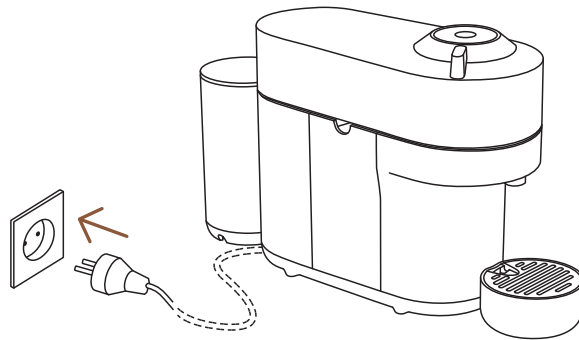

- 2** Kytke virtajohto.



- 3** Seuraa **Nespresso**-sovelluksen ohjeita.

**HUOM:** Lue ensin turvallisuusvarotoimet, välttyäksesi kohtalokkaan sähköiskun tai tulipalon vaaralta. Varmista maadoitus kytkettäessä konetta virtalähteeseen.

- \* App Store® on Apple Inc:n tavaramerkki, joka on rekisteröity Yhdysvalloissa ja muissa maissa.  
 \*\* Google Play ja Google Play -logo ovat Google LLC:n tavaramerkkejä.

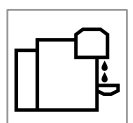

## KONEEN BLUETOOTHIN JA WI-FI:N POISTAMINEN KÄYTÖSTÄ

Koneessa on yhdistettävyysoiminto, joka on oletuksena käytössä. Se antaa pääsyn lisäominaisuuksiin, jotka parantavat kahvielämystäsi. Poistaaksesi yhdistettävyysoiminnon, seuraa näitä ohjeita:

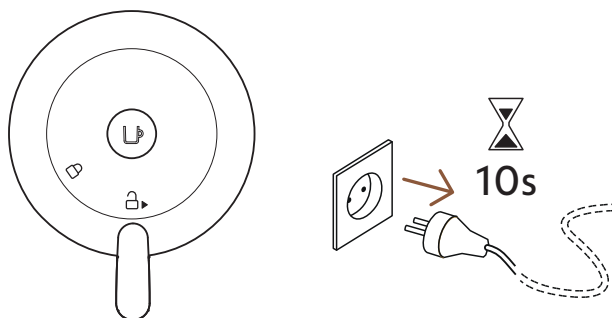

- 1** Kun kone on suljettu ja vipu **auki-asennossa**, irrota kone pistorasiasta vähintään 10 sekunniksi.

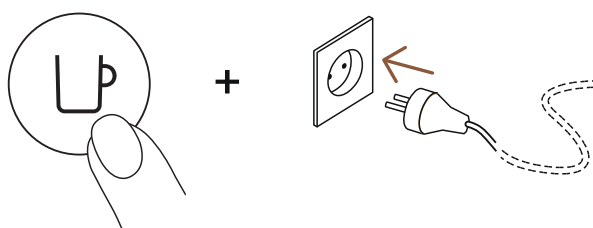

- 2** Paina painiketta pohjaan laittaessasi virtajohdon pistokkeeseen. Painike vilkuu oranssina vahvistaakseen että yhdistettävyysoiminto on kytketty pois päältä.

- i** Seuraa samoja ohjeita kytkeäksesi yhdistettävyysoiminnon takaisin päälle. Painike vilkuu valkoisena vahvistaakseen että toiminto on kytketty uudelleen päälle.

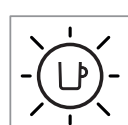
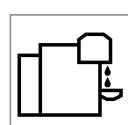
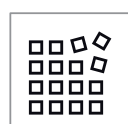

# ENSIMMÄINEN KÄYTTÖKERTA

## ENSIMMÄINEN HUUHTELU

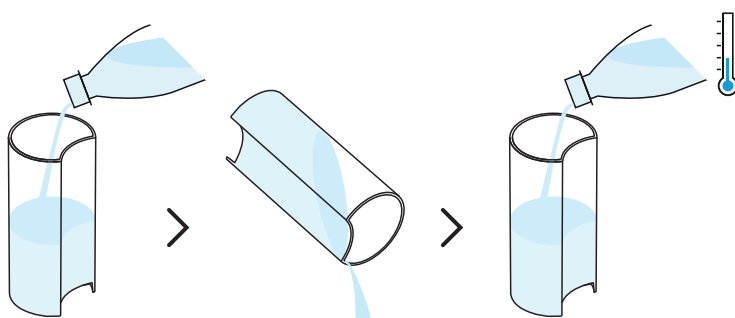

- 1** Huuhtele ja puhdista vesisäiliö ja kansi ennen kuin täytät säiliön puhtaalla juomavedellä.

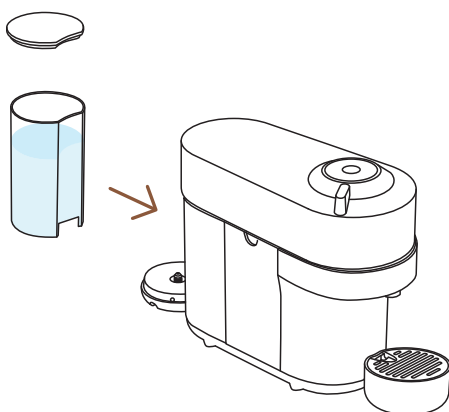

- 2** Sulje vesisäiliö kannella ja aseta säiliö paikalleen ja pidä huolta että se on asetettu oikein.

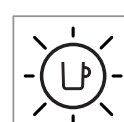
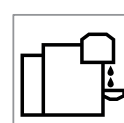
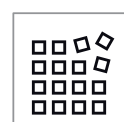
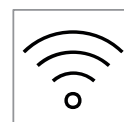

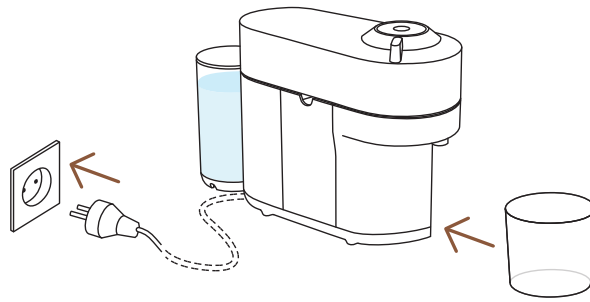

- 3** Kytke virtajohto, irrota kupin tuki ja aseta tyhjä astia (vähintään 1 litran vetoinen) kahvisuuttimen alle.

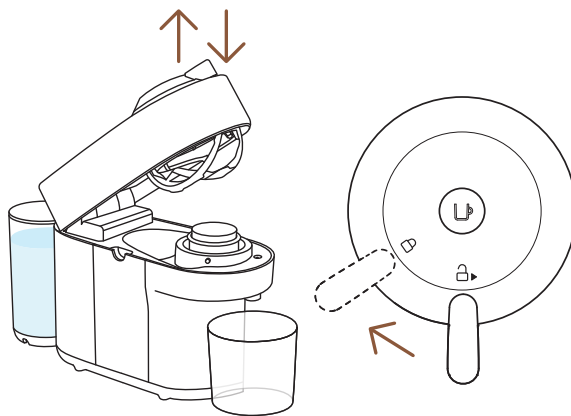

- 4** Avaa ja sulje kone. Pidä huolta että kahva on lukittu.

- i** Valo vilkkuu kun kone lämpenee. Tämä vie noin 30 sekuntia. Kun valo palaa tasaisesti, kone on valmis. Varmista että koneen sisällä ei ole kahvikapselia.

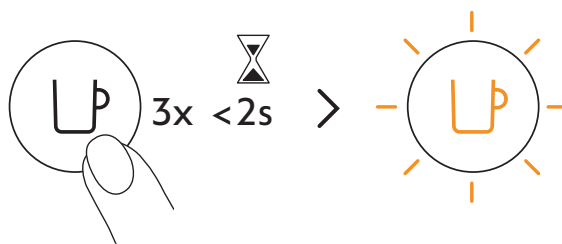

- 5** Paina painiketta kolme kertaa kahden sekunnin sisään aloittaaksesi huuhtelun. Aloita huuhtelu painamalla painiketta 3 kertaa 2 sekunnin sisällä. Anna huuhtelun päättyä automaattisesti.

- i** Vie alle kaksi minuuttia, kunnes huuhtelutoiminto alkaa ja vesi alkaa virrata. Tämä vaihe voi kestää 7 minuuttia.



## KAHVIN VALMISTUS

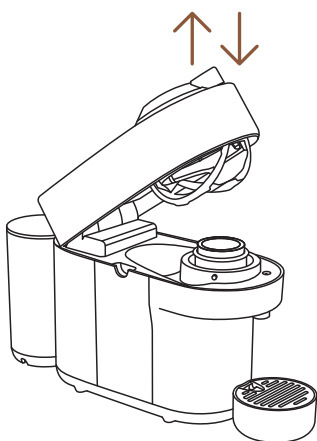

**1** Avaa ja sulje kone.

**i** Kahvipainikevalo vilkkuu kun kone lämpenee. Kun valo palaa tasaisesti, kone on valmis käytettäväksi.

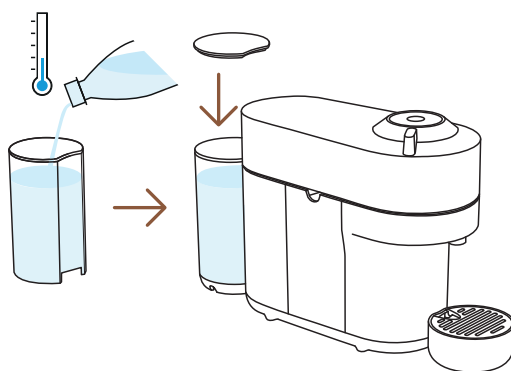

**2** Täytä vesisäiliö raikkaalla juomavedellä ja aseta se paikalleen.

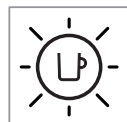
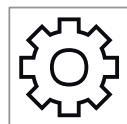
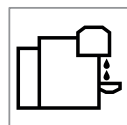
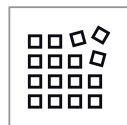
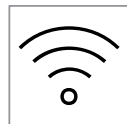

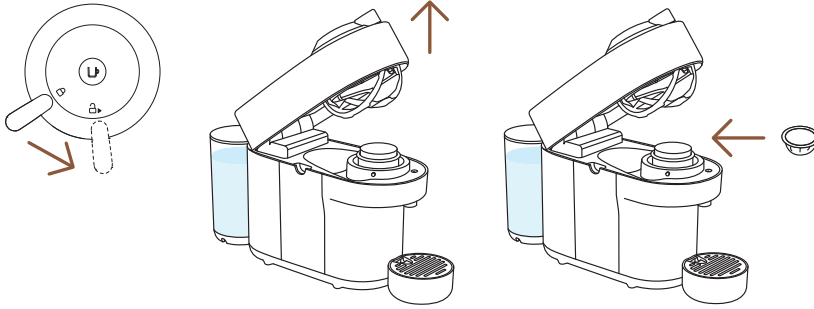

- 3** Avaa koneen kansi kokonaan ja aseta sisään Vertuo-kahvikapseli, pyöreä puoli alaspäin.

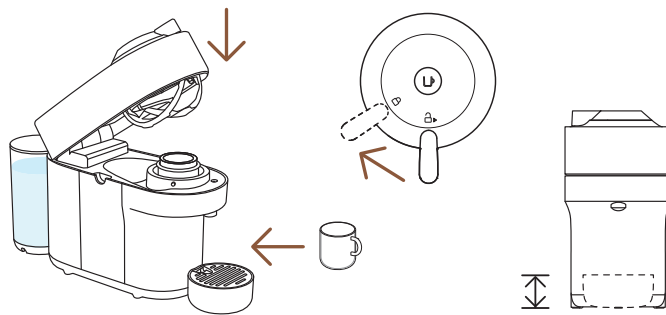

- 4** Sulje koneen kansi ja lukitse kääntämällä vipua vasemmalle lukitusasentoon ja aseta kuppi paikalleen. Kupintuki voidaan säätää kupin koon mukaan.

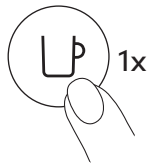

- 5** Aloita valmistus painamalla painiketta kerran.

**VAROITUS:** koneen oikean käytön varmistamiseksi älä avaa koneen kanta kahvin valmistamisen aikana, vaan odota, kunnes kone on pysähtynyt ja kahvipainike palaa tasaisesti valkoisena. Mikäli haluat lopettaa haudutuksen aikaisemmin, paina kahvipainiketta kerran ja odota, kunnes kahvipainike palaa tasaisen valkoiseksi.

- i** Viivakoodin lukemisen, kahvin esikostutuksen ja infuusioajan vuoksi kestää hetken ennen kuin kahvi alkaa virrata. Kone tunnistaa automaattisesti asetetun kapselin ja valitsee **Nespresso** kahviasiantuntijoiden määrittämät valmistusparametrit sekä kahvin määrän, valmistaakseen optimaalisen kupillisen.

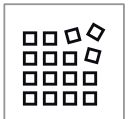
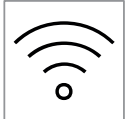

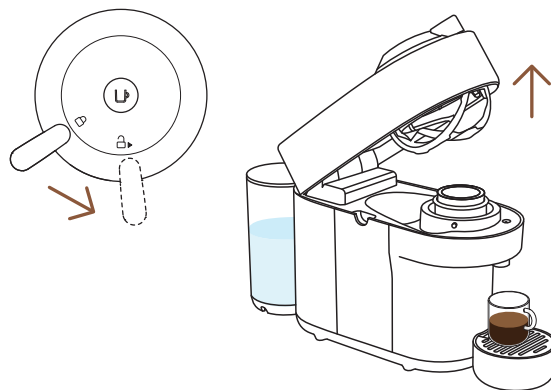

- 6** Kun kahvin tulo loppuu, avaa koneen kahva kääntämällä vipua oikealle avausasentoon, poistaaksesi kapselin ja nauttiaksesi kahvistasi.



- 7** Kiitos kun kierrätät **Nespresso**-kahvikapselisi.\*

\* TÄMÄ ON **NESPRESSO**. TÄMÄ ON KIERRÄTETTÄVÄÄ. Lue lisätietoa **Nespresso**-kahvikapseleiden kierrätyksestä osoitteessa [www.nespresso.fi](http://www.nespresso.fi)

## TUTUSTU COFFEE CREATIONS -TILAAN



Tällä kahvikoneella **Nespresso** tarjoaa erityisen toiminnon keskittyäksesi kahvinvalmistukseen ja luodaksesi omia reseptejasi.

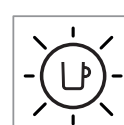
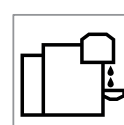
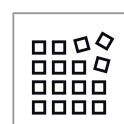
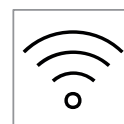

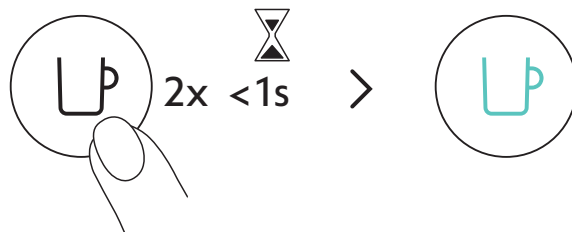

Kun kone on päällä, tuplaklikkaa kahvipainiketta. Valo palaa turkoosina ja kahvinvalmistuksesi keskitetään, mikä optimoi kahvin maun resepteissä, joissa on lisäaineita (maito, kerma, jäitä...). Vertaamattomia kahvielämyksiä varten.

40 ml	80 ml	150 ml	230 ml	355 ml	535 ml
✓	✓	✓	✓	✗	✗
25 ml	40 ml	40 ml	80 ml		

Jotta voit nauttia kaikista eduista, suosittelemme Coffee+ -valikoimamme valmistamista käyttämällä vain virallisia kahvikuppikokoja. Parhaan kupillisen lopputuloksen saavuttamiseksi emme suosittele XL (Alto Ambrato, Alto Onice) Cold Brew Style & Carafe Pour Over Style -kahvien valmistamista tässä tilassa.

**HUOMAUTUS:** Koneesi päivitys **Nespresso**-sovelluksen kautta saattaa olla tarpeen tämän tilan käyttöön ottamiseksi.

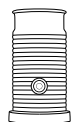

Lue kuinka voit parantaa kahvielämystäsi Aeroccino-mallistollamme [www.nespresso.fi](http://www.nespresso.fi)

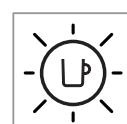
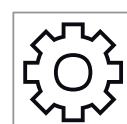
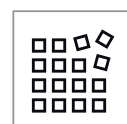
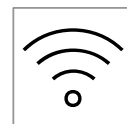

# SÄÄDÄ KAHVISI MÄÄRÄÄ

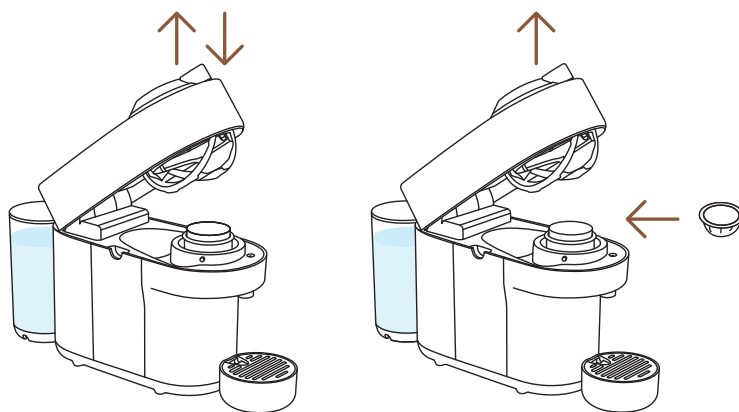

- 1** Avaa kahvikone ja aseta kahvikapseli jonka asetuksia haluat muuttaa.

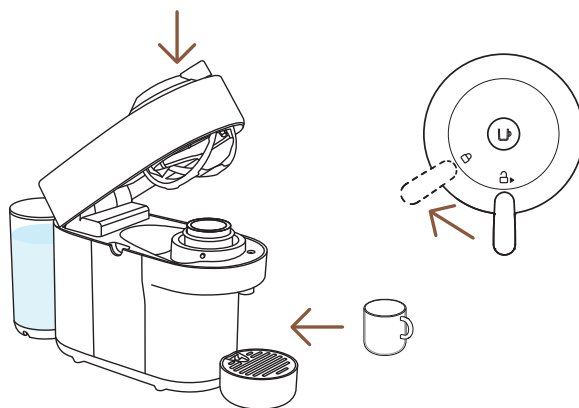

- 2** Sulje koneen kansi, käännä vipua vasemmalle lukitusasentoon ja aseta kuppi.

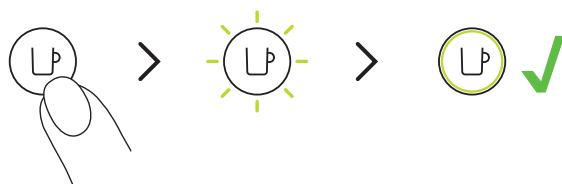

- 3** Pidä painiketta painettuna, päästää irti muutama sekunti ennen, kunnes haluttu kahvin määrä on saavutettu. Nyt veden määrä on asetettu valitsemalessi kapselille.

- i** Laitteen ohjelmointi on kapselikohtainen. Kahvien koot voi ohjelmoida välille 20 ml – 535 ml.

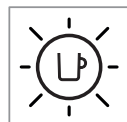
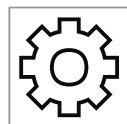
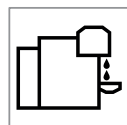
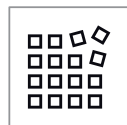
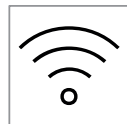

**VAROITUS:** koneen oikean käytön varmistamiseksi älä avaa koneen kantta kahvin valmistamisen aikana, vaan odota, kunnes kone on pysähtynyt ja kahvipainike palaa tasaisen valkoisena. Mikäli haluat lopettaa valmistuksen aikaisemmin, paina kahvipainiketta kerran ja odota, kunnes kahvipainike palaa tasaisen valkoiseksi.

**HUOMAUTUS:** Kun kapselikohtainen määrä on ohjelmoitu käyttäjän toimesta, kyseinen kapseli valmistuu aina uudelleen käyttäjän valitsemalle määrälle. Mikäli haluat palauttaa oletusparametreihin, katso kohta “Palauta tehdasasetukset”.

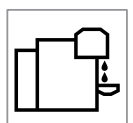

## PUHDISTAMINEN

Puhdista koneesi kuukausittain, kun alat saamaan kahvin ylijäämää koneen sisälle tai pitkän käyttämättäjäättämisen jälkeen.

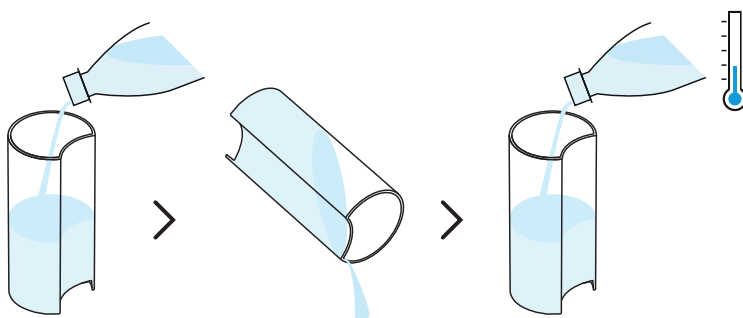

- 1** Huuhtele ja puhdista vesisäiliö ja kansi ennen kuin täytät säiliön raikkaalla juomavedellä.

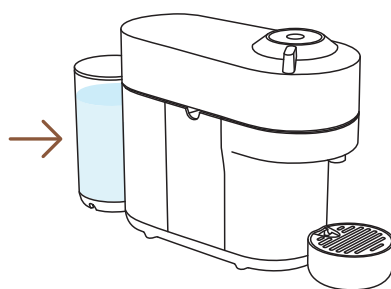

- 2** Aseta vesisäiliö takaisin paikalleen koneeseen.

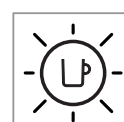
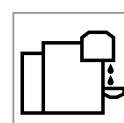
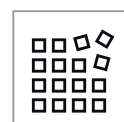
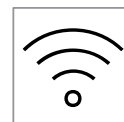

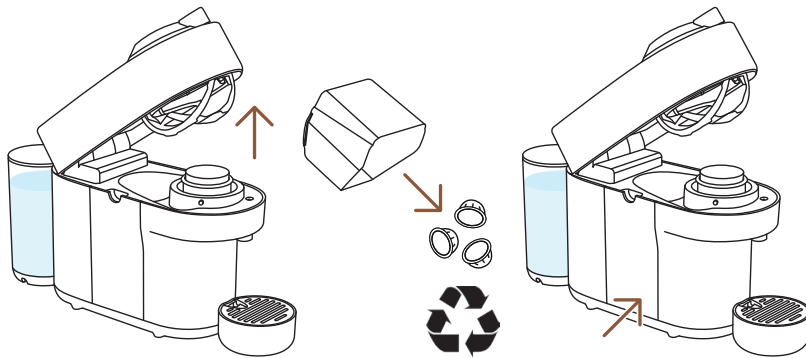

- 3** Avaa kahvikone ja anna käytetyn kapselin tippua säiliöön. Tyhjennä ja huuhtele käytettyjen kapseleiden säiliö ja tippa-alusta, ja aseta ne takaisin paikalleen. Kiitos kun kierrätät **Nespresso**-kahvikapselisi.\*

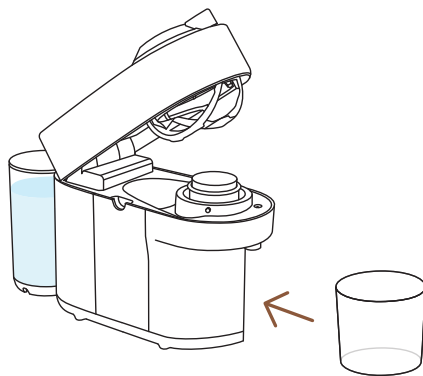

- 4** Poista kupin tuki ja aseta kahvisuuttimen alle tyhjä nestesäiliö (väh. 1L vetoinen).

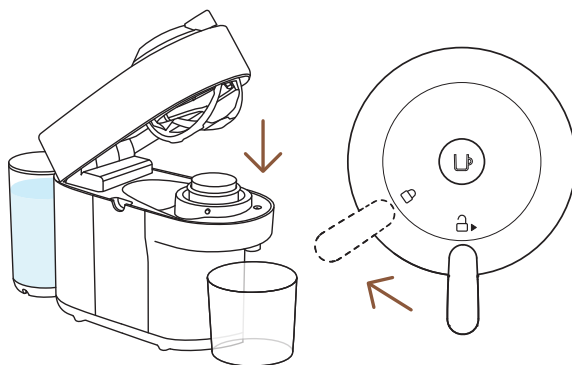

- 5** Sulje kansi ja käännä vipua vasemmalle lukitusasentoon. Varmista, että koneessa ei ole kapseleita ennen puhdistustoimenpiteen aloittamista.

\* TÄMÄ ON **NESPRESSO**. TÄMÄ ON KIERRÄTETTÄVÄÄ. Lue lisätietoa **Nespresso**-kahvikapselien kierrätyksestä osoitteessa [www.nespresso.fi](http://www.nespresso.fi)

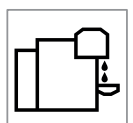

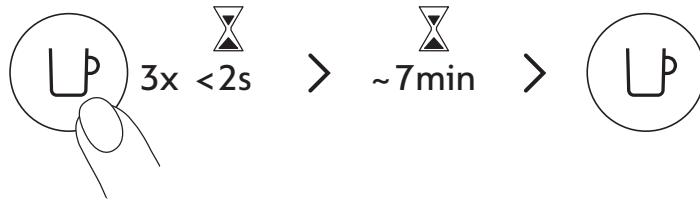

**6** Paina painiketta kolme kertaa kahden sekunnin sisään aloittaaksesi huuhtelun. Anna puhdistusprosessin päättyä automaattisesti.

**i** Kestää alle 2 minuuttia ennen kuin puhdistusprosessi alkaa ja vettä alkaa virrata. Tämä toiminto saattaa viedä seitsemän minuuttia ja se loppuu automaattisesti kun toiminto on valmis. Toiminnon voi keskeyttää koska tahansa painamalla painiketta

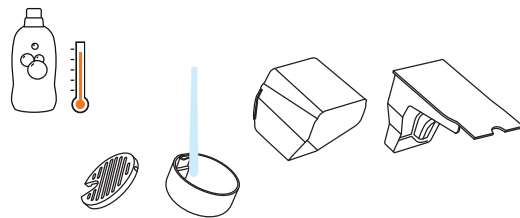

**7** Pese kapselisäiliö, kupin tuki ja tippa-alusta kuumalla vedellä ja miedolla hajusteettomalla pesuaineella.

**HUOM:** Älä käytä voimakkaita tai hankaavia pesuaineita tai välineitä. Älä laita konetta pesukoneeseen. Älä koskaan kasta laitetta tai osaa siitä veteen tai muuhun nesteeseen.

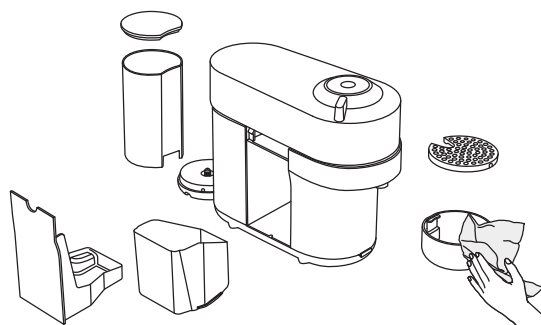

**8** Kuivaa puhtaalla ja raikkaalla pyyhkeellä

**HUOM:** Puhdista kahvisuutin säännöllisesti puhtaalla ja kostealla liinalla. Käytä aina pehmeää liinaa puhdistaksesi koneen.

**HUOMAUTUS:** Koneen kannen sisään voi kerääntyä vettä, kuivaa näkyvät osat puhtaalla ja kuivalla liinalla.

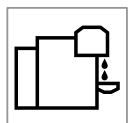
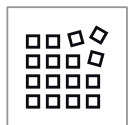

## KALKINPOISTO

Kalkinpoisto pitää huolen että koneesi toimii oikein koko käyttöikänsä ajan, ja että kahvielämyksesi on yhtä hyvä kuin ensimmäisenä käyttöpäivänä. Koneesi ilmoittaa kun kalkinpoisto on tarpeen vilkuttamalla oranssia valoa kolme kertaa ennen kuin se vaihtuu valkoiseksi tasaisesti palavaksi valoksi.



**i** Kalkinpoistotoiminto kestää noin 20 minuuttia ja **sitä ei voi keskeyttää.**

**HUOMIO:** Lue huolellisesti kalkinpoisto-ohjeet ennen aloittamista.

### Tarvitset:

- Kalkinpoistosesti on saatavana [www.nespresso.fi](http://www.nespresso.fi)
- Tyhjä astia (1 L vetoinen)

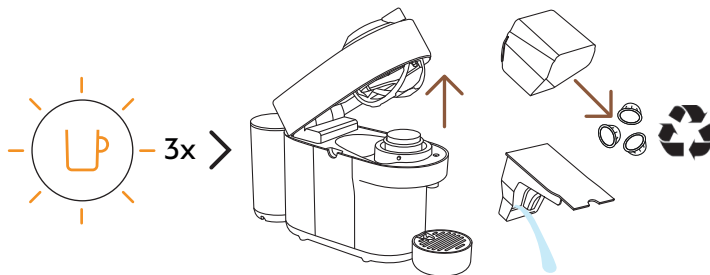

**1** Kun oranssi valo vilkkuu kolme kertaa: Avaa koneen kansi ja vapauta käytetty kapseli. Tyhjennä kapselisäiliö ja tippa-alusta ja aseta ne takaisin paikoilleen. Kiitos kun kierrätät käytetyt **Nespresso**-kahvikapselisi.\*

\* TÄMÄ ON **NESPRESSO**. TÄMÄ ON KIERRÄTETTÄVÄÄ. Lue lisätietoa **Nespresso**-kahvikapseleiden kierrätyksestä osoitteessa [www.nespresso.fi](http://www.nespresso.fi)



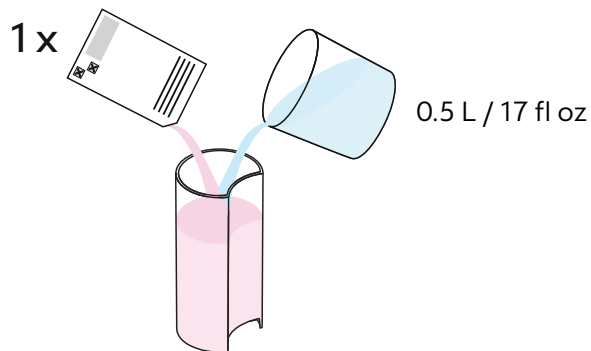

- 2** Täytä vesisäiliö 0.5 L vedellä ja lisää yksi yksikkö **Nespresso** kalkinpoistoliuosta.

**HUOM:** Huomioithan että kalkinpoistoliuos voi olla haitallista. Vältä kontaktia silmien, ihon ja pintojen kanssa.

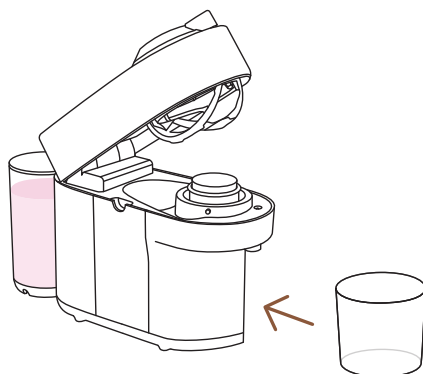

- 3** Poista kupin tuki ja aseta kahvisuuttimen alle tyhjä astia (väh. 1 L vetoinen).

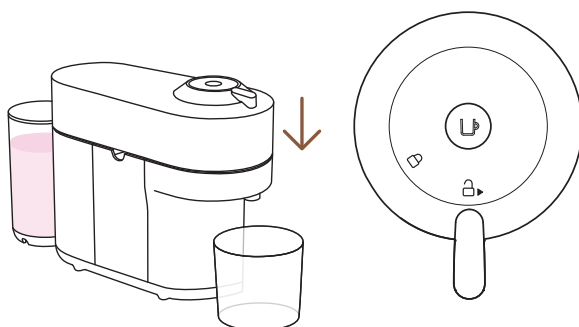

- 4** Kun kone on päällä, sulje koneen kansi ja jätä vipu aukiasentoon.

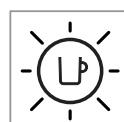
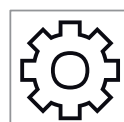
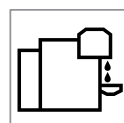
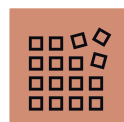
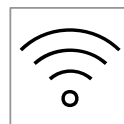

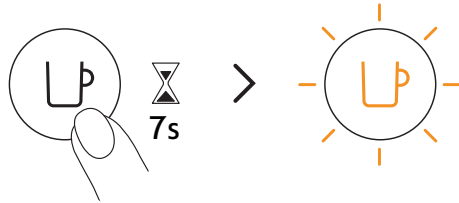

- 5** Paina painiketta ainakin seitsemän sekunnin ajan tai kunnes valo sammuu. Valo alkaa vilkkumaan nopeasti oranssina.

**HUOM:** Sinulla on 45 sekuntia aikaa mennä kalkinpoistotilaan, muuten kone palaa takaisin valmistustilaan.

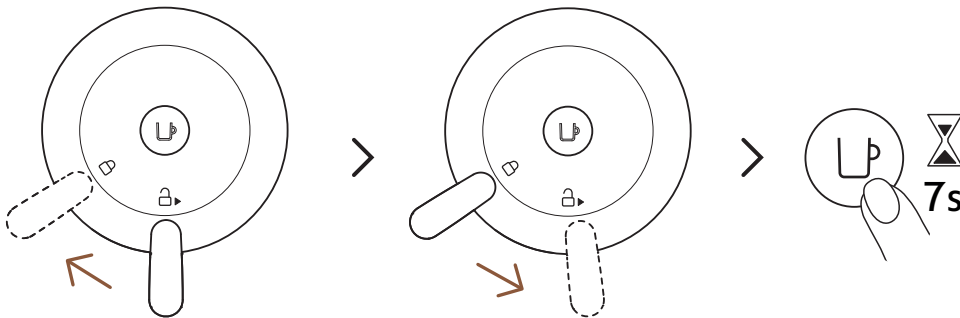

- 6** Sulje koneen kansi kääntämällä vipua vasemmalle lukon kuvaan asti ja avaa vipu kääntämällä sitä oikealle avausasentoon. Paina ja pidä pohjassa painiketta noin seitsemän sekunnin ajan tai niin kauan kunnes valo sammuu. Painike alkaa vilkuttamaan oranssia valoa nopeasti.

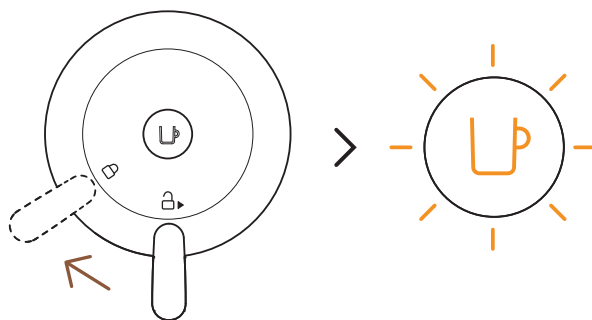

- 7** Päästäksesi kalkinpoistotilaan, lukitse kone kääntämällä vipua vasemmalle lukitusasentoon. Oranssi valo jatkaa vilkkumista. Tämä kertoo että olet kalkinpoistotilassa.

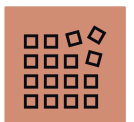

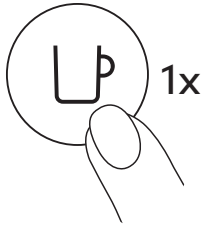

- 8** Aloita kalkinpoisto painamalla kahvipainiketta kerran. Valo vilkkuu jatkuvasti oranssina koko prosessin ajan.

- i** Kone lopettaa automaattisesti kun kalkinpoiston ensimmäinen vaihe on valmis.

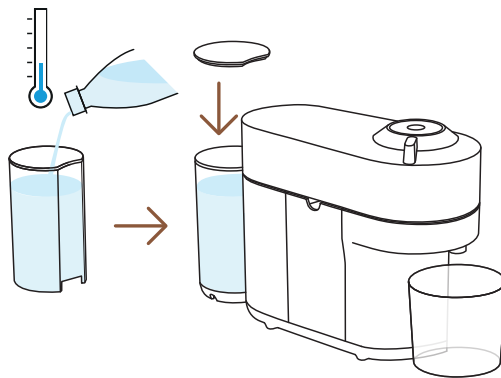

- 9** Kalkinpoistoprosessin päätyttyä, on aika huuhdella kone. Huuhtelee vesisäiliö ja tippa-alusta huolellisesti. Täytä vesisäiliö raikkaalla juomavedellä ja aseta takaisin paikalleen. Tyhjennä säiliö ja aseta se kahvisuuttimen alle.

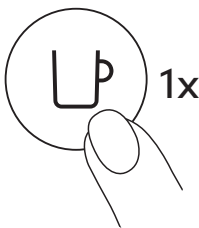

- 10** Paina painiketta aloittaaksesi huuhtelun. Kun valo ensin vilkkuu nopeasti ja sen jälkeen palaa tasaisesti, tämä tarkoittaa että kalkinpoistoprosessi on valmis.

- i** Kone lopettaa automaattisesti kun prosessi on valmis.

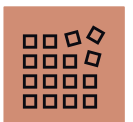

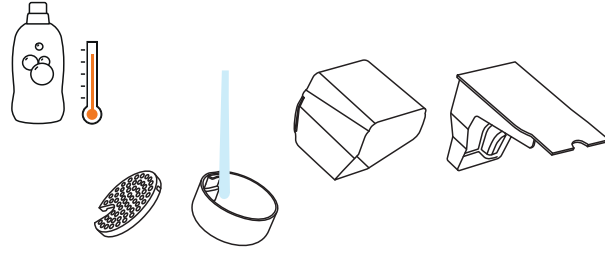

- 11** Pese kapselisäiliö, kupin tuki ja tippa-alusta kuumalla vedellä ja miedolla, hajusteettomalla pesuaineella.

**HUOM:** Älä käytä voimakkaita tai hankaavia pesuaineita tai välineitä. Älä laita konetta astianpesukoneeseen. Älä koskaan kasta konetta tai osaa siitä veteen tai muuhun nesteeseen.

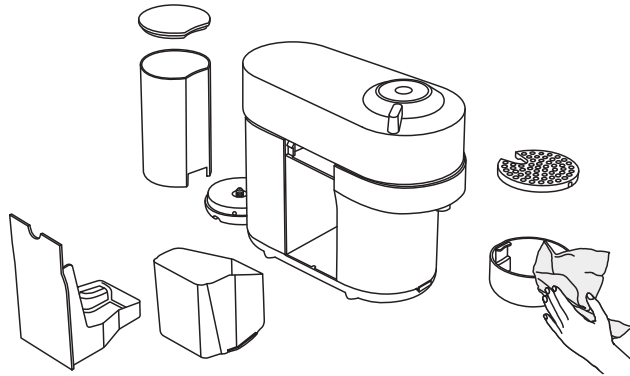

- 12** Kuivaa kone puhtaalla ja raikkaalla pyyheellä. Anna koneen kuivua 10 minuutin ajan ennen seuraavaa käyttöä.

**HUOMAUTUS:** Vettä saattaa kertyä koneen kahvan sisään puhdistuksen aikana. Mikäli tämä tapahtuu, kuivaa näkyvät osat puhtaalla ja kuivalla pyyheellä.

**HUOMIO:** kone voi siirtyä kalkinpoistotilaan vasta, kun 30 tai enemmän kahvia on valmistettu.

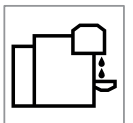
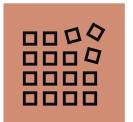

## JÄRJESTELMÄN TYHJENTÄMINEN

Järjestelmän tyhjentäminen on prosessi, mikä tulisi tehdä pitkän käyttämättömyysajan valmistamiseksi, pakkassuojaksi tai kahvikoneen huollon vuoksi.

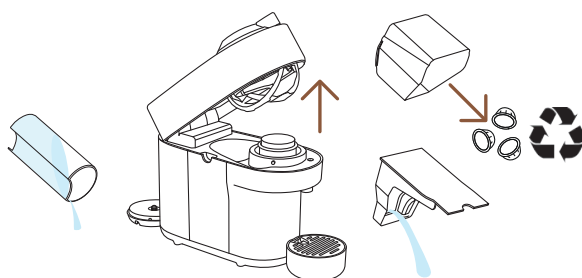

- 1** Tyhjennä vesisäiliö, avaa koneen kansi ja poista käytetty kapseli. Tyhjennä kapselisäiliö ja tippa-alusta. Kiitos kun kierrätät **Nespresso**-kahvikapselisi.\*

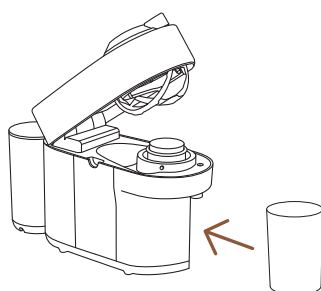

- 2** Aseta ne takaisin paikoilleen koneeseen, poista kupin tuki ja aseta kahvisuuttimen alle tyhjä astia (0.5 L).

\*TÄMÄ ON **NESPRESSO**. TÄMÄ ON KIERRÄTETTÄVÄÄ. Lue lisätietoa **Nespresso**-kahvikapselien kierrätyksestä osoitteessa [www.nespresso.fi](http://www.nespresso.fi)

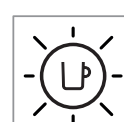
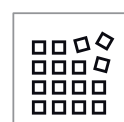
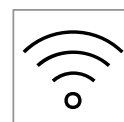

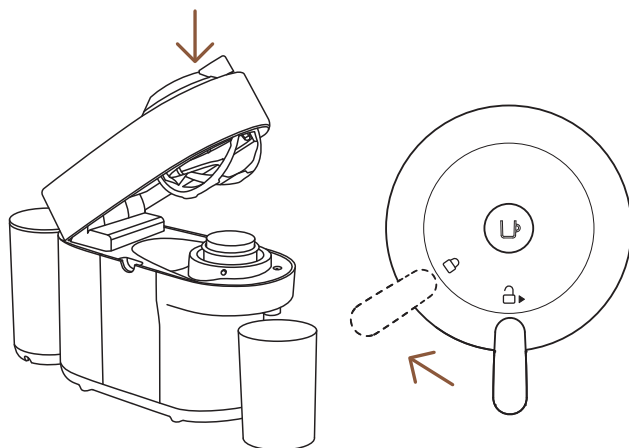

- 3** Kun kone on kytketty, avaa ja sulje koneen kansi ja käännä vipu lukitusasentoon.

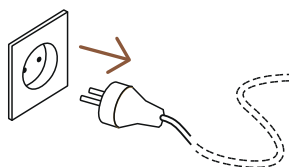

- 4** Irrota virtajohto pistorasiasta

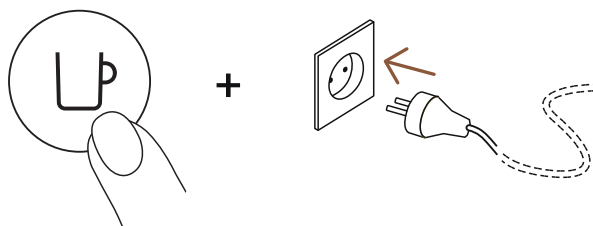

- 5** Paina painiketta pohjaan laittaessasi virtajohdon pistokkeeseen

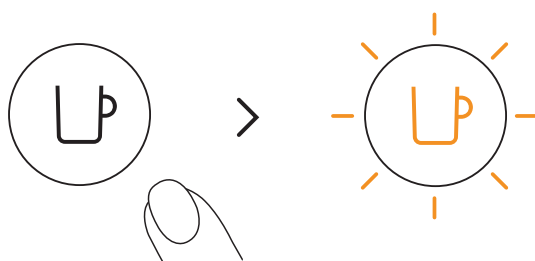

- 6** Vapauta painike. Se vilkkuu oranssina ja tyhjennysprosessi alkaa.

- i** Vie noin 30 sekuntia kun kone saattaa tyhjennysprosessin loppuun. Kone sammuu automaattisesti kun se on valmis.

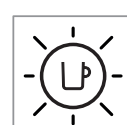
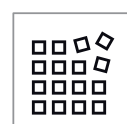
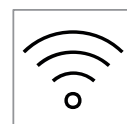

## PALAUTA TEHDASASETUKSET

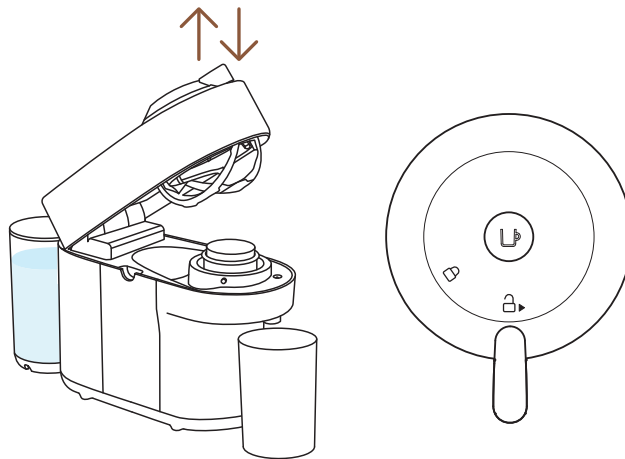

- 1** Kun kone on kytketty, avaa ja sulje koneen kansi ennen kuin jätät vivun **avausasentoon**.

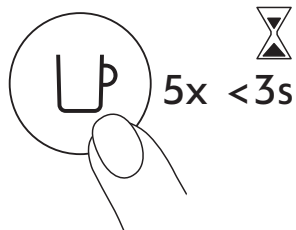

- 2** Paina kahvipainiketta viidesti kolmen sekunnin sisään. Kone on nyt ohjelmoitu tehdasasetuksiin.



## MERKKIVALOJEN YHTEENVETO

Haluatko oppia lisää Vertuo POP:n merkkivaloista?  
Ole hyvä ja katso seuraava video:

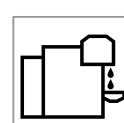
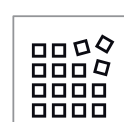
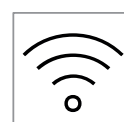

## VIANMÄÄRITYS

### Kahvipainikkeessa ei ole valoa

- Kahvikone on mennyt pois päältä automaattisesti; käynnistä kahvikone painamalla kahvipainiketta tai avaamalla se
- Tarkista pistoke, jännite ja sulake.

### Kahvi ei valu, eikä vettä tule.

- Tarkista, että vesisäiliössä on vettä.
- Tarkista, että kahvikapseli on asetettu oikein paikalleen ja että kahvikoneen kansi on suljettu. Käynnistä kahvikone painamalla kahvipainiketta.
- Suorita tarvittaessa kalkinpoisto
- Avaa kahvikoneen kansi ja odota käytetyn kahvikapselin poistumista. Suorita tämän jälkeen puhdistustoimenpiteet puhdistusohjeiden mukaisesti.

### Kahvi ei ole riittävän kuumaa.

- Esilämmitä kahvikuppi kuumalla hanavedellä.
- Suorita tarvittaessa kalkinpoisto

### Vuoto tai kahvin valuminen epätavallisesti.

- Tarkista, että vesisäiliö on asetettu oikein paikalleen.
- Suorita tarvittaessa kalkinpoisto

### Kahvikone menee pois päältä.

- Kahvikoneessa on automaattinen virrankatkaisu kahden minuutin kuluttua edellisen käytön jälkeen.
- Kone voidaan sammuttaa manuaalisesti milloin tahansa (kun ei käytössä) painamalla ja pitämällä painiketta pohjassa kolmen sekunnin ajan.

### Kupissa on kahvinporoja.

- Suorita puhdistustoiminto kahdesti.
- Lue "[Kahvikoneen puhdistus](#)"-osio.

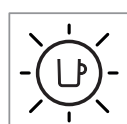
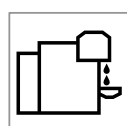
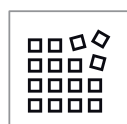
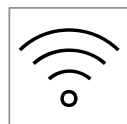

**Kahvikone ei aloita kahvin valuttamista ja kahvipainikkeessa on tasaisesti palava valo. Jos valo välkkyi, katso seuraavat kohdat.**

- Tarkista, että kahvikoneen vipu on lukitusasennossa.
- Jos haluat valmistaa kahvin tai espresson, tarkista, että uusi kahvikapseli on asetettu oikeaan asentoon ja että vipu on lukittu kunnolla. Käynnistä kahvikone painamalla kahvipainiketta.
- Jos olet suorittamassa kahvikoneen puhdistus-, tyhjennys- tai kalkinpoistotoimintoa, niin tarkista, että kahvikapseli on poistunut, sulje kansi ja lukitse kahvikone. Käynnistä haluamasi toiminto kahvipainiketta painamalla.



**Kahvikone ei käynnisty ja merkkivalo vilkkuu vuorotellen: yksi välähdys ja yksi tauko.**

- Täytä vesisäiliö ja käynnistä kahvikone painamalla kahvipainiketta.
- Tarkista, että kahvikoneen vipu on lukitusasennossa.

**Merkkivalo vilkkuu, kun kahvikone on käynnissä.**

- Jos kahvi valuu normaalisti, kahvikone toimii oikein.
- Kahvikoneen puhdistus-, kalkinpoisto- tai tyhjennystoiminto on käynnissä, jos kahvikoneen suuttimesta valuu vain vettä. Tarkista käyttöohjeet "Kahvin määrän ohjelmointi" -kohdasta.
- Sammuta kahvikone painamalla kahvipainiketta kolmen sekunnin ajan ja paina kahvipainiketta käynnistääksesi kahvikoneen uudelleen. Odota nyt noin 20 minuuttia, jotta kahvikone voi jäähtyä.

**Kahvikone ei käynnisty ja merkkivalo vilkkuu vuorotellen: yksi välähdys ja yksi tauko.**

- Kahvin valumisen alkaminen kestää hieman viivakoodin lukemisen ja kahvin esikastelun vuoksi.
- Tarkista, että kahvikapseli on asetettu oikein paikalleen ja että kahvikoneen kansi on suljettu. Käynnistä kahvikone painamalla kahvipainiketta.
- Täytä vesisäiliö ja käynnistä kahvikone painamalla kahvipainiketta.
- Sammuta kahvikone painamalla kahvipainiketta kolmen sekunnin ajan ja paina kahvipainiketta käynnistääksesi kahvikoneen uudelleen. Odota nyt noin 20 minuuttia, jotta kahvikone voi jäähtyä.

**Valo vilkkuu vuorotellen: kaksi välähdystä ja yksi tauko. Kahvikone ei ole käynnissä.**

- Tarkista tavallisen kahvin ja espresson valmistuksen aikana, että:
  - 1) Uusi ja ehjä kahvikapseli on asetettu oikeaan asentoon. Käännä vipua lukituksen vapauttamiseksi ja avaa kahvikoneen kansi.
  - 2) Kahvikoneen vipu on lukitusasennossa.
  - 3) Tarkista, että vesisäiliössä on vettä.
- Tarkista kalkinpoisto-, tyhjennys- ja puhdistustoimintojen aikana, että:
  - 1) Käytetty kahvikapseli on poistunut.
  - 2) Kahvikoneen vipu on lukitusasennossa.
- Tarkista kahvin määrän ohjelmoinnin aikana, että:
  - 1) Varmista että kapseli on hyvin paikoillaan.
  - 2) Tarkista käyttöohjeet **“Kahvin määrän ohjelmointi”** -kohdasta.
- Jos ongelma jatkuu:
  - 1) Avaa kahvikone kääntämällä vivusta ja avaamalla kahvikoneen kansi
  - 2) Vaihda kapseli (tarvittaessa).
  - 3) Irrota kahvikoneen virtajohto pistorasiasta ja kytke kahvikone uudelleen pistorasiaan 10 sekunnin kuluttua.
  - 4) Sulje kahvikoneen kansi ja paina kahvipainiketta aloittaaksesi kahvin valmistuksen.

Jos ongelma jatkuu, ota yhteyttä **Nespresso**n asiakaspalveluun

**Valo vilkkuu vuorotellen kolmesti ja jää sitten pysyvästi päälle.**

- Kalkinpoisto on tarpeen: kahvia voidaan valmistaa tämän merkkivaloilmoituksen jälkeen vain muutaman kerran ennen kuin kalkinpoisto on pakollista suorittaa.

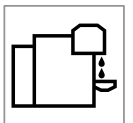
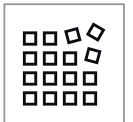

## TEKNISET TIEDOT

<b>Teho</b>	<b>~220–240 V, 50–60 Hz, 1300–1500 W</b> <b>US, CA:</b> 120 V, 60 Hz, 1500 W <b>MX:</b> 127 V~, 60 Hz, 1380 W
<b>Taajuus</b>	2.402–2.480 GHz
<b>RF-ulostulon teho (EIRP)</b>	Bluetooth 4 dBm Max. e.i.r.p. ja Wi-Fi <20 dMm max. e.i.r.p.
<b>Valmiustila</b>	0.39 W/h
<b>Virransäästötila</b>	Energiansäästötila: 2 min
<b>Lämmitysaika</b>	30 sekuntia (kansi suljettu ja lukittu)
<b>Säädettävä kupin tuki isoja reseptejä varten</b>	Irrotettava asento
<b>Virtajohdon pituus</b>	75 cm
<b>Mitat (L x S x K)</b>	13.6 x 42.6 x 25 cm / 5.3 x 16.7 x 9.8 in
<b>Paino</b>	3.5 kg / 7.72 lbs
<b>Vesisäiliön tilavuus</b>	0.6 l / 20 fl oz
<b>Kapselisäiliön vetoisuus</b>	8 espresso- tai 5 Muki-kapselia

## KONEEN KOODIT

Nespresso	Breville	Delonghi
GCV2, GDV2	BNV120, BNV150	ENV90
Krups	Magimix	
XN9201, XN9204, XN9205, XN9211	M800	

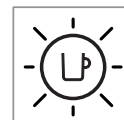
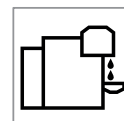
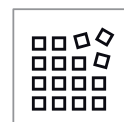
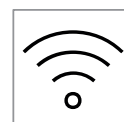

# KLICKA OCH VÄLJ SPRÅK

SV



**SÄKERHET**



**ÖVERSIKT**



**ANSLUTNING**



**FÖRSTA STEGEN**



**KAFFEFÖRBEREDELSE**



**ANPASSA DIN KAFFEMÄNGD**



**RENGÖRING**



**AVKALKNING**



**TÖMNING AV SYSTEMET**



**ÅTERSTÄLL TILL FABRIKSINSTÄLLNINGAR**



**SAMMANFATTNING BLINKNINGAR**



**FELSÖKNING**



**SPECIFIKATIONER**

## SÄKERHET

**VARNING:** Innan du använder din kaffemaskin, var vänlig läs igenom säkerhetsinstruktionerna för att undvika potentiell fara och skada.

### AVFALLSHANTERING OCH MILJÖSKYDD

Denna maskin uppfyller EU-direktiv 2012/19/EG.

Förpackningsmaterial och maskin innehåller återvinningsbara material. Din maskin innehåller värdefulla material som kan återvinnas. Separering av återstående avfallsmaterial till olika typer underlättar återvinning av värdefulla råvaror. Lämna maskinen på en samlingspunkt för återvinning. Du kan få information om bortskaffande från din lokala myndighet.

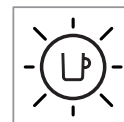
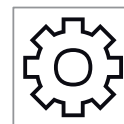
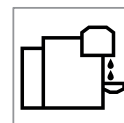
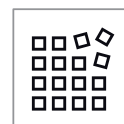
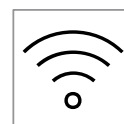

# ÖVERSIKT

## MASKINÖVERSIKT

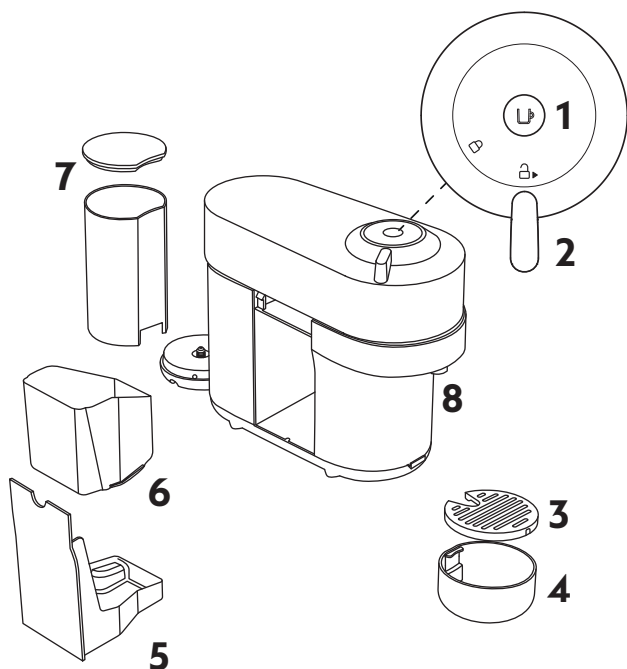

- 1 PÅ/AV och kaffeknapp
- 2 Låsa/Låsa upp spak
- 3 Droppgaller
- 4 Justerbar kopphållare
- 5 Droppbricka
- 6 Behållare för använda kapslar
- 7 Vattentank och lock
- 8 Kaffeutlopp

## FÖRPACKNINGENS INNEHÅLL



- 1 Kaffemaskin
- 2 **Nespresso** kapselbox
- 3 **Nespresso** välkomstmateriel
- 4 Säkerhetsinstruktioner
- 5 Snabbstarts-guide
- 6 Garanti

4 + 5 + 6

**i Uppackning:** Det kan finnas damm på maskinen på grund av det återvunna materialet som används i förpackningen. Detta är inte farligt, rengör helt enkelt med en mjuk trasa.

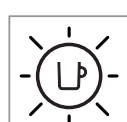
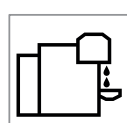
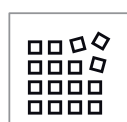
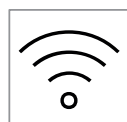

## ÖPPNA/STÄNG

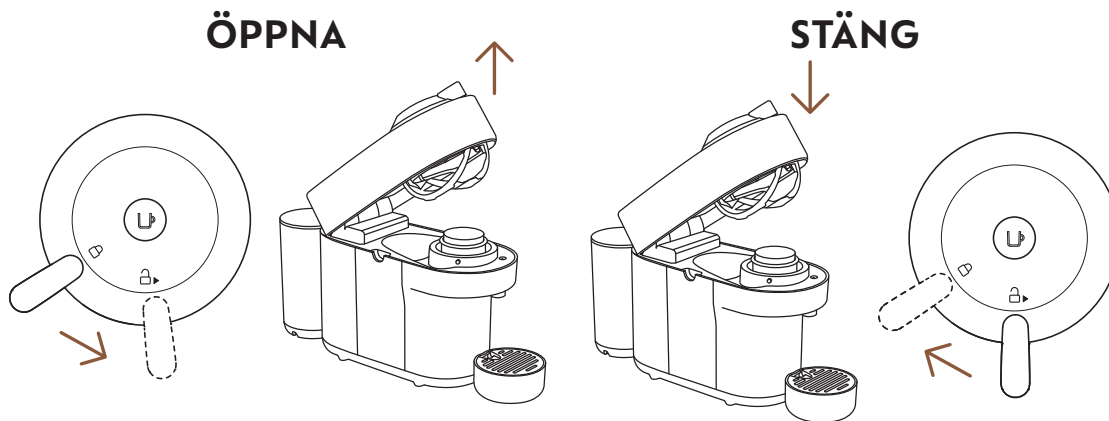

**OBSERVERA:** För korrekt användning av maskinen, öppna inte maskinhuvudet medan maskinen brygger. Vänta till kaffeknappen lyser stadigt vitt. Om du vill stoppa bryggningen tidigare, tryck en gång på kaffeknappen och vänta tills maskinen stoppar innan du öppnar maskinhuvudet.

## VERTUO-SYSTEMET

## KAPSELKOMPATIBILITET

**S****Ristretto**

(25 ml)

**Espresso**

(40 ml)

**M****Double Espresso**

(80 ml)

**Gran Lungo**

(150 ml)

**L****Mug**

(230 ml)

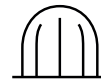
**XL****Alto, Cold Brew Style**

(355 ml)

**Carafe**

(535 ml)

## TILLBEHÖRSKOMPATIBILITET



Tillbehörskompatibilitet

**Ristretto****Espresso****Double Espresso****Gran Lungo****Mug (S)****Mug (M)****Reveal-glas**

Inte lämpliga tillbehör

**Mug (L)****Carafe**

Upptäck hela vår accessoarkollektion på [www.nespresso.com](http://www.nespresso.com)

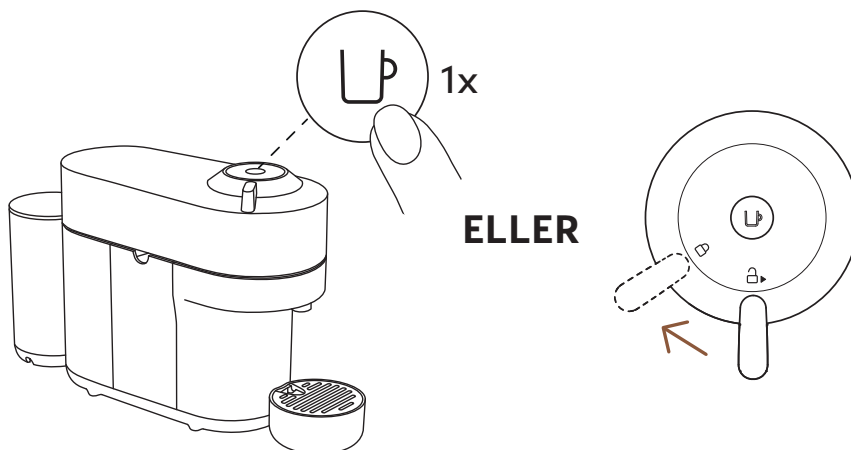

## PÅ/AV

**PÅ**

När maskinen är inkopplad, starta genom att trycka på knappen en gång eller genom att stänga spaken i låst position (med huvudet stängt).

- i** Lampan kommer att blinka i cirka 30 sekunder medan maskinen värms upp. När lampan är stadig, är maskinen redo att användas.

**AV**

För att spara energi kommer maskinen stänga av sig efter 2 minuter utan användning.

- i** Maskinen kan stängas "AV" manuellt när som helst (när den inte används) genom att trycka och hålla ned knappen i 3 sekunder.

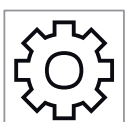
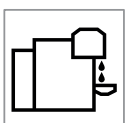
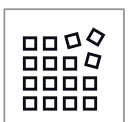

## ANSLUTNING

### VARFÖR DU SKA PARKOPPLA DIN VERTUO POP KAFFEMASKIN

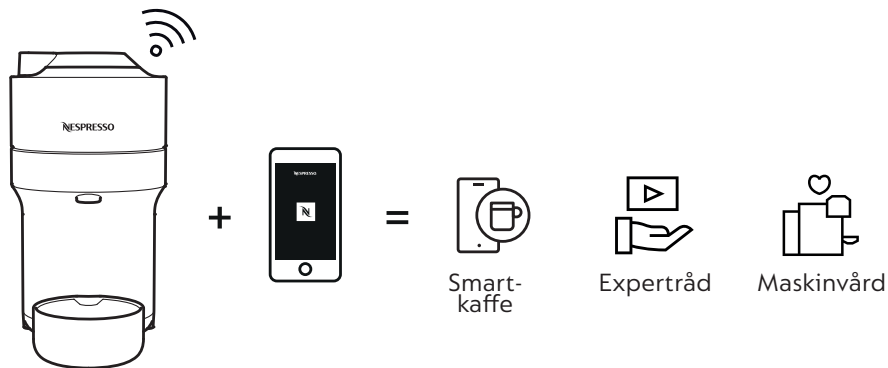

### FÖRDELAR MED ATT KOPPLA UPP DIN VERTUO POP-MASKIN

- **Smart-kaffe:** Håll dig alltid steget före för att få det senaste inom kaffeinnovation från **Nespresso** genom att hålla din maskin i toppskick och uppdaterad.
- **Expertråd:** Få support och enkla handledningsvideor som följer med din kafferesa via din smartphone.
- **Maskinvård:** Få omedelbar notifikation om när och hur du ska serva din maskin med en enkel guide för avkalkning, sköljning, rengöring, osv.

### HUR MAN KOPPLAR UPP SIN VERTUO POP-MASKIN?

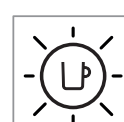
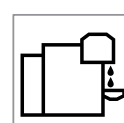
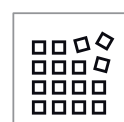

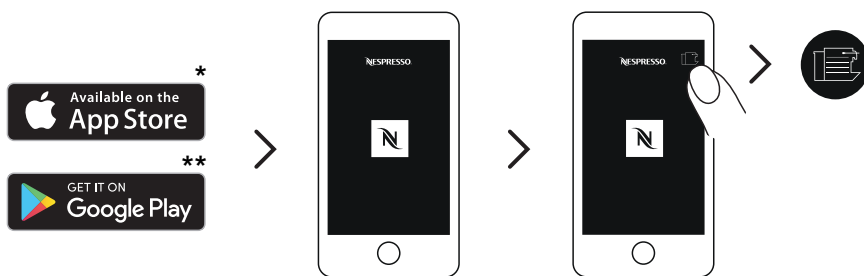

- 1** Ladda ner eller uppdatera **Nespresso**-appen. Starta **Nespresso**-appen på din smartphone eller surfplatta. Tryck på maskinikonen längst upp till höger på din skärm.

**NOTERA:** För optimalt utförande och en smidig upplevelse rekommenderar vi att du ansluter din maskin till en Wi-Fi router istället för en smartphone-hotspot.

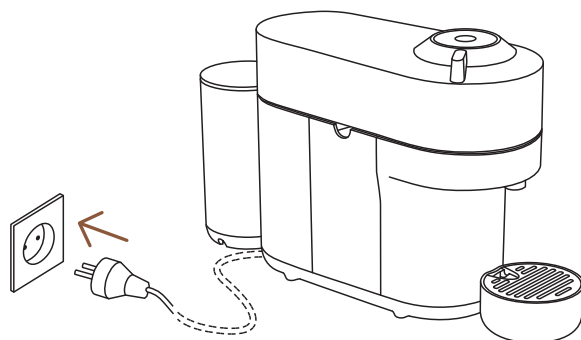

- 2** Koppla in strömkabeln.



- 3** Följ instruktionerna via **Nespresso**-appen.

**WARNING:** Läs först säkerhetsföreskrifterna för att undvika risker för allvarliga elchockar och brand. Se till att jordförbindelsen är korrekt när du sätter in maskinen i eluttaget.

- \* App Store® är ett varumärke som tillhör Apple Inc., registrerat i USA och andra länder
- \*\* Google Play och Google Play-logotypen är varumärken som tillhör Google LLC.

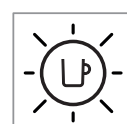
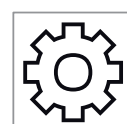
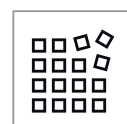
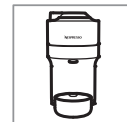

## INAKTIVERA BLUETOOTH OCH WI-FI PÅ MASKINEN

Maskinen levereras med en anslutningsmodul som är aktiverad som standard. Det ger tillgång till ytterligare funktioner som förbättrar din kaffeupplevelse. För att inaktivera anslutningsmodulen följer du dessa steg:

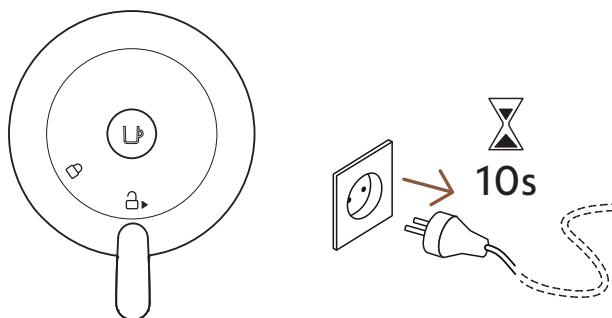

- 1 Med maskinen stängd och spaken i **upplåst** position, koppla ur maskinen i minst 10 sekunder.

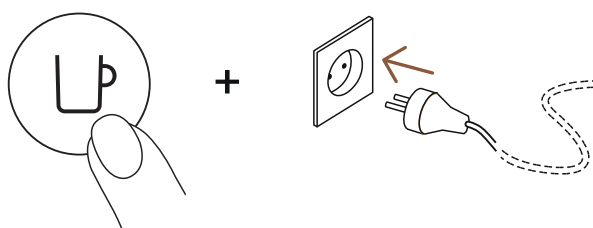

- 2 Tryck och håll ned knappen när du kopplar i kontakten. Knappen kommer att blinka orange för att bekräfta att anslutningsmodulen nu har inaktiverats.

- i** Följ samma steg för att aktivera anslutningsmodulen igen. Knappen kommer att blinka vit för att bekräfta att modulen har aktiverats igen.

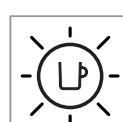
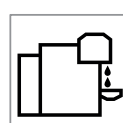
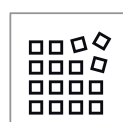

# FÖRSTA STEGEN

## FÖRSTA RENGÖRING

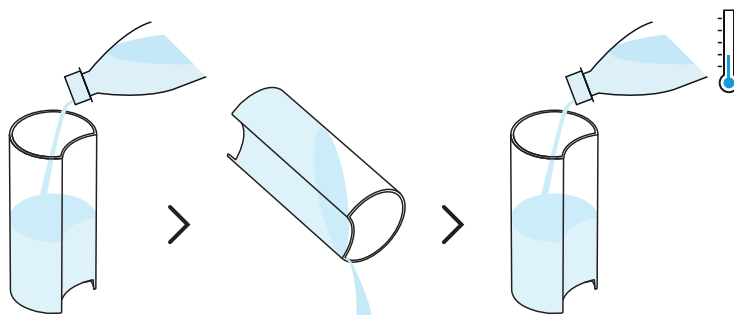

- 1** Skölj och rengör först vattentanken och locket innan du fyller den med färskt dricksvatten.

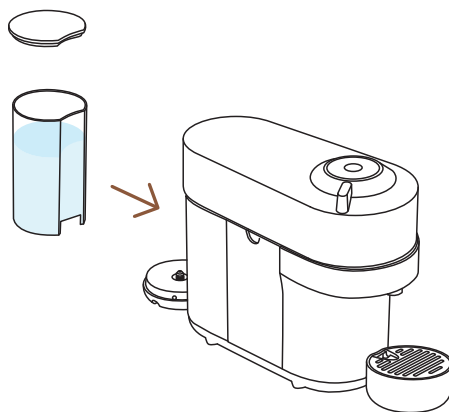

- 2** Stäng vattentanken med locket och se till att den sitter ordentligt på plats.

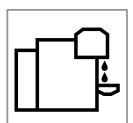

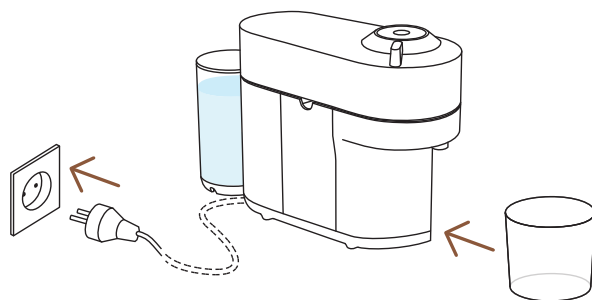

- 3** Med maskinen inkopplad, ta bort kopphållaren och placera en tom behållare (på minst 1 L) under kaffeutloppet.

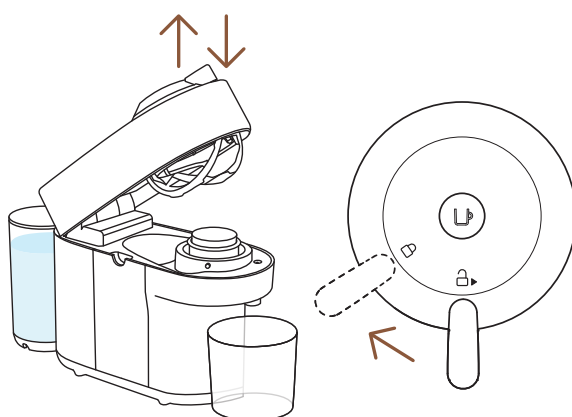

- 4** Öppna och stäng maskinen. Se till att spaken är i låst position.

- i** Lampan kommer att blinka medan maskinen värms upp. Det tar cirka 30 sekunder. När lampan är stadig är maskinen redo. Se till att ingen kapsel är insatt.

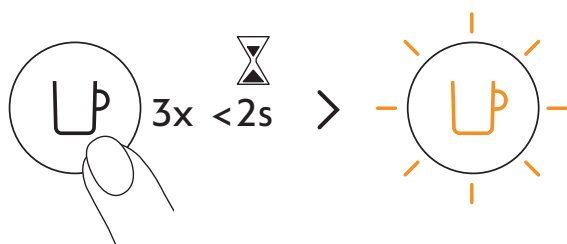

- 5** Tryck på knappen 3 gånger inom 2 sekunder för att börja skölja. När lampan blinkar orange, låt sköljningsproceduren slutföras automatiskt. När lampan lyser stadigt vitt är cykeln klar.

- i** Det bör ta mindre än 2 minuter innan sköljningsprocessen börjar och vatten börjar strömma. Detta kan ta upp till 7 minuter.

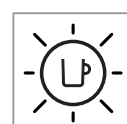
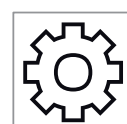
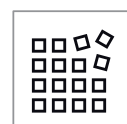
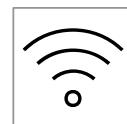

# KAFFEFÖRBEREDELSE

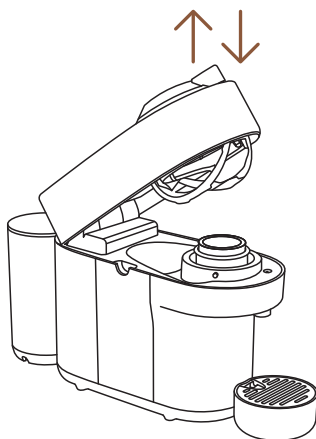

**1** Öppna och stäng maskinen.

**i** Lampan på kaffeknappen kommer att blinka medan maskinen värms upp. När lampan är stadig är maskinen redo att användas.

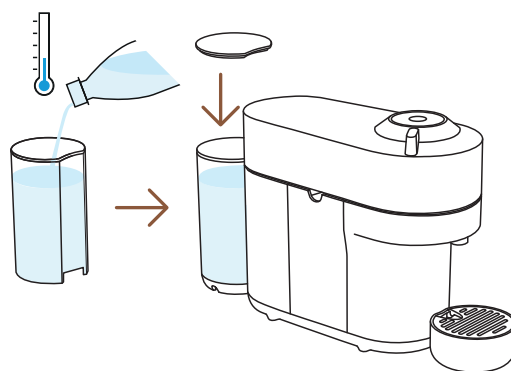

**2** Fyll tanken med färskt dricksvatten och placera tillbaka den på plats.

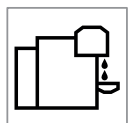

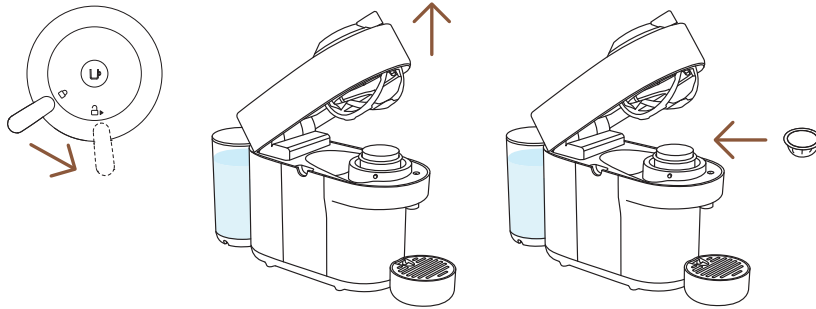

- 3** Lås upp och öppna maskinhuvudet helt och sätt i en Vertuo-kapsel med den höga sidan nedåt.

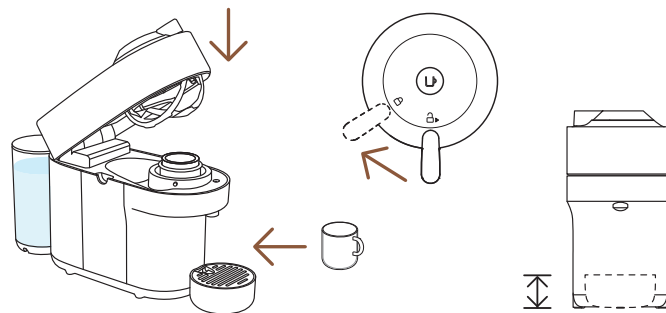

- 4** Stäng maskinhuvudet och lås genom att vrida spaken åt vänster tills låsställning och placera en kopp. Kopphållaren kan justeras för att rymma din koppstorlek.

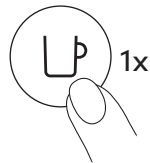

- 5** Börja brygga genom att trycka på knappen en gång.

**OBSERVERA:** För korrekt användning av maskinen, öppna inte maskinhuvudet medan maskinen brygger. Vänta till kaffeknappen lyser stadigt vitt. Om du vill stoppa bryggningen tidigare, tryck en gång på kaffeknappen och vänta tills maskinen stoppar innan du öppnar maskinhuvudet.

- i** På grund av streckkodsläsningen, kaffe-precipitationen och infusionstiden tar det en stund innan kaffet börjar strömma. Maskinen känner automatiskt igen den insatta kapseln och väljer kaffeberedningsparametrar och kopplängd som definierats av **Nespresso**-kaffeexperter för att extrahera kaffeblandningarna på bästa sätt.

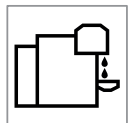
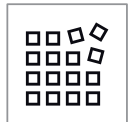

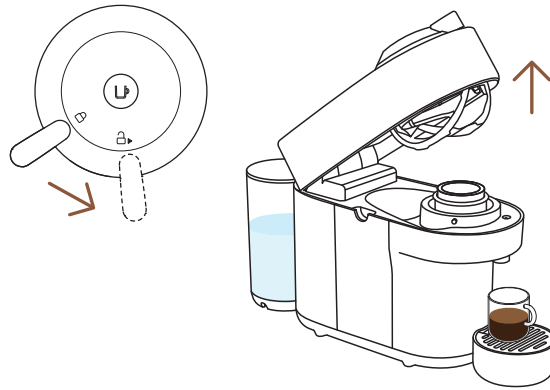

- 6** När kaffet slutar brygga, öppna maskinhuvudet genom att vrida spaken åt höger mot upplåst läge för att automatiskt mata ut kapseln och njut av ditt kaffe. När kaffet slutar brygga, öppna maskinen, mata ut kapseln och njut av ditt kaffe.



- 7** Glöm inte att återvinna dina **Nespresso**-kapslar.\*

\* **DETTA ÄR NESPRESSO. DETTA ÄR ÅTERVINNINGSBART.** För mer information om återvinning av dina **Nespresso** kaffekapslar, besök [www.nespresso.com](http://www.nespresso.com)

## UPPTÄCK VÅR KAFFERECEPT-FUNKTION.



Med denna maskin erbjuder **Nespresso** dig en specifik funktion för att koncentrera dina kaffebryggingar och skapa dina egna recept.

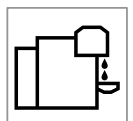
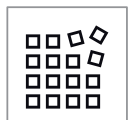

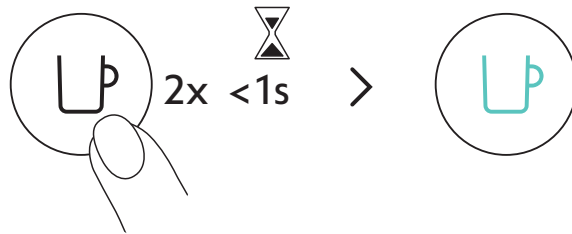

Med din maskin på, dubbelklicka på kaffeknappen. Det kommer att blinka turkos och din kaffebruggning kommer att vara koncentrerad, vilket optimerar kaffesmaken i recept med tillsatser (mjölk, grädde, över is ...). För en oslagbar kaffeupplevelse.

40 ml	80 ml	150 ml	230 ml	355 ml	535 ml
✓	✓	✓	✓	✗	✗
25 ml	40 ml	40 ml	80 ml		

För att njuta av alla fördelar rekommenderar vi att du brygger vårt Coffee+-sortiment enbart som de officiella koppstorlekarna. För det bästa koppresultatet rekommenderar vi inte att brygga våra XL (Alto Ambrato, Alto Onice), Cold Brew Style & Carafe Pour Over Style med denna funktion.

**NOTERA:** En uppdatering av din maskin via **Nespresso**-appen kan vara nödvändig för att aktivera denna funktion.



Upptäck hur du kan uppgradera din maskin med vår Aeroccino-serie på [www.nespresso.com](http://www.nespresso.com).

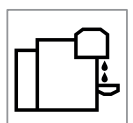

## ANPASSA DINA KAFFESTORLEKAR

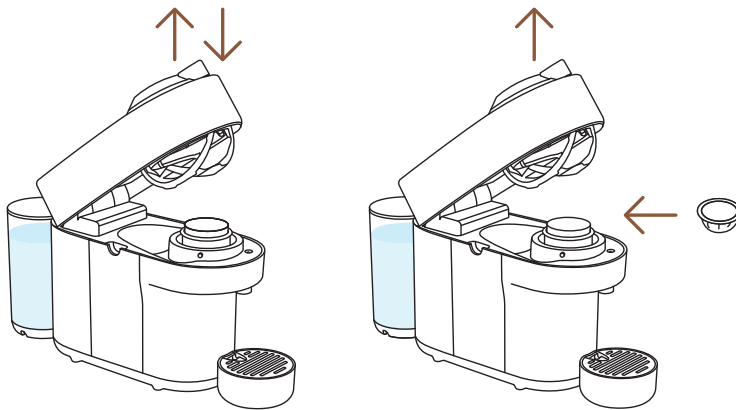

- 1** Med maskinen på, öppna maskinen och lägg i kapseln som du vill programmera.

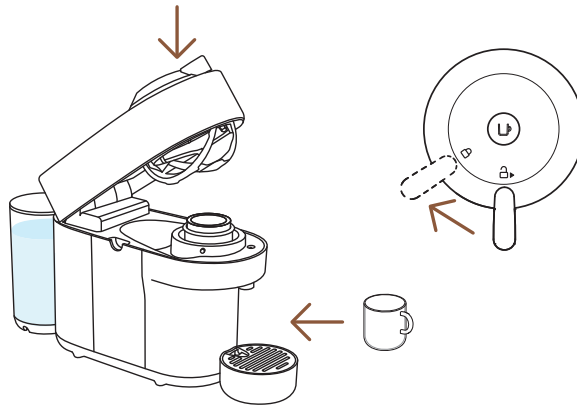

- 2** Stäng maskinhuvudet, vrid spaken åt vänster mot låsställning och placera en kopp.

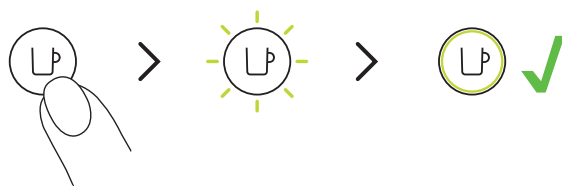

- 3** Tryck och håll ner knappen, släpp några sekunder innan önskad mängd har uppnåtts. Den nya vattenmängden är nu programmerad för kapseltypen som användes under inställningen.

- i** Programmeringen är specifik för varje kapseltyp. Koppstorleken är programmerbar från 20 ml till 535 ml.

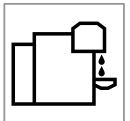

**OBSERVERA:** För korrekt användning av maskinen, öppna inte maskinhuvudet medan maskinen brygger. Vänta till kaffeknappen lyser stadigt vitt. Om du vill stoppa bryggningen tidigare, tryck en gång på kaffeknappen och vänta tills maskinen stoppar innan du öppnar maskinhuvudet.

**NOTERA:** När en kundspecifik volym programmeras av användaren, kommer varje gång den typen av kapsel sätts in i maskinen, förberedelsen att stanna vid den koppstorleken som användaren har programmerat. Om du vill återgå till standardinställningarna, se avsnittet **“Återställning till fabriksinställningar”**.

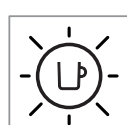
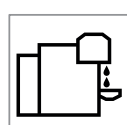
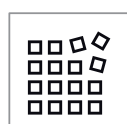
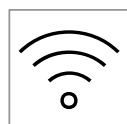

# RENGÖRING

Rengör maskinen en gång i månaden, när det börjar dyka upp kaffefläckar inuti maskinhuvudet eller efter en lång tidsperiod utan användning.

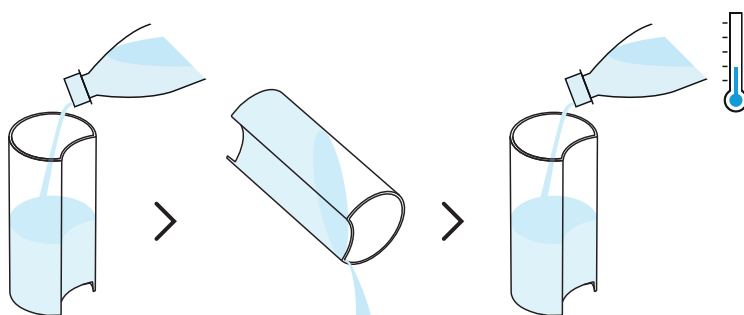

- 1** Skölj och rengör vattentanken och locket innan du fyller den med färskt dricksvatten.

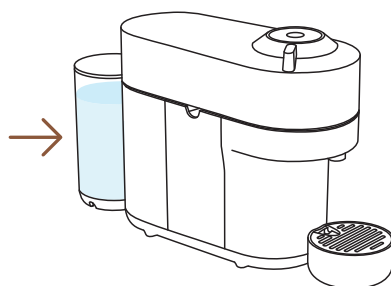

- 2** Sätt tillbaka vattentanken på maskinen.

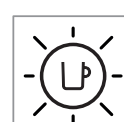
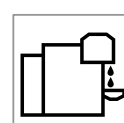
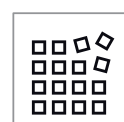
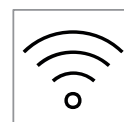

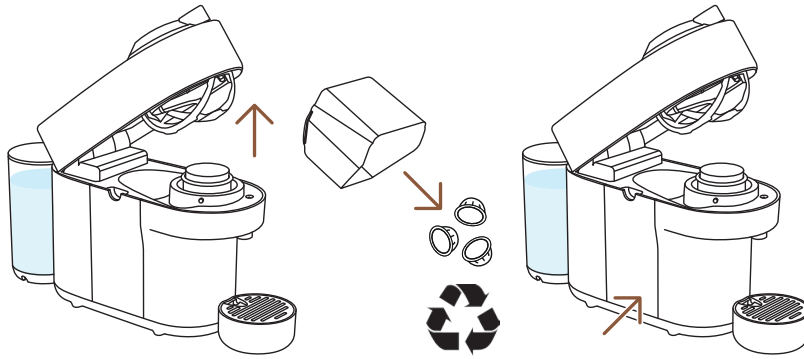

- 3** Med maskinen på, lås upp och öppna maskinen och låt den använda kapseln bli utkastad. Töm och skölj kapselbehållaren och droppbrickan och sätt tillbaka dem på plats. Glöm inte att återvinna dina **Nespresso**-kapslar.\*

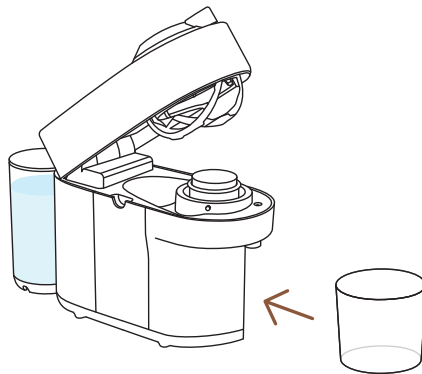

- 4** Ta bort kophållaren och placera en tom behållare (på minst 1 L) under kaffeutloppet.

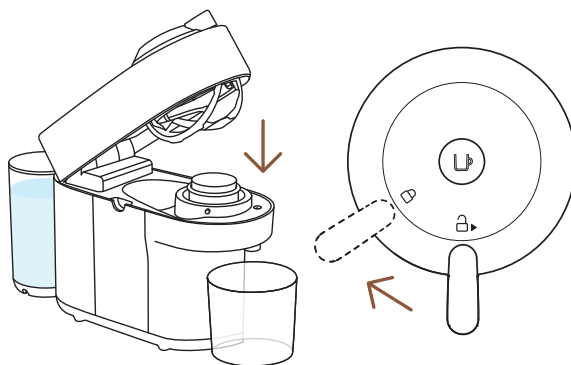

- 5** Stäng maskinhuvudet och vrid spaken till vänster mot låst position. Se till att det inte finns några kapslar i maskinen innan du startar sköljningsproceduren.

\* DETTA ÄR **NESPRESSO**. DETTA ÄR ÅTERVINNINGSBART. För mer information om återvinning av dina **Nespresso** kaffekapslar, besök [www.nespresso.com](http://www.nespresso.com)

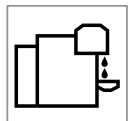
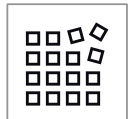

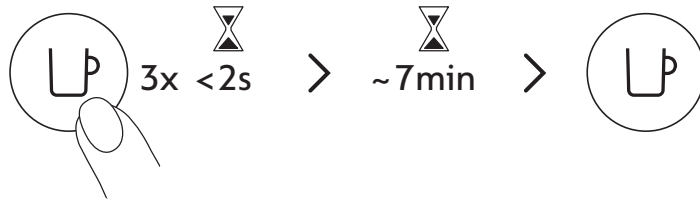

- 6** Tryck på knappen 3 gånger inom 2 sekunder för att börja skölja. När lampan blinkar orange, låt rengöringsproceduren slutföras automatiskt.

- i** Det bör ta mindre än 2 minuter innan sköljningsprocessen börjar och vattnet börjar flöda. Denna process kan ta upp till 7 minuter och kommer att stoppa automatiskt när cykeln är klar. Processen kan stoppas när som helst genom att trycka på knappen

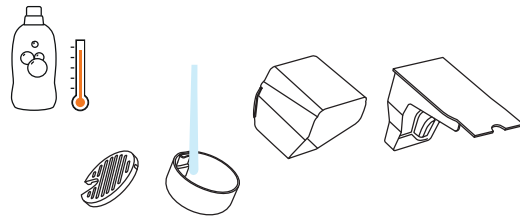

- 7** Tvätta kapselbehållaren, koppållaren och droppbrickan med varmt vatten och mild doftlöst rengöringsmedel.

**VARNING:** Använd inte starka eller slipande rengöringsmedel eller lösningsmedel. Sätt inte in maskinen i diskmaskinen. Sänk aldrig ned apparaten eller delar av den i vatten.

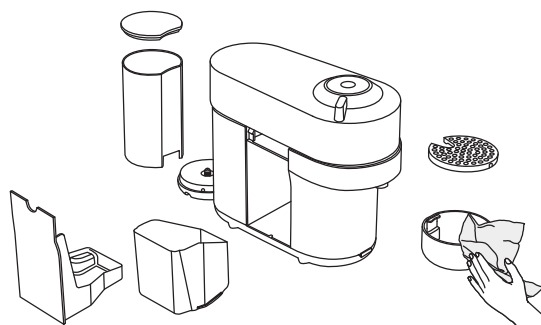

- 8** Torka med en ren handduk.

**VARNING:** Rengör kaffeutloppet regelbundet med en ren fuktig trasa. Använd alltid mjuka trasor för att rengöra maskinen.

**NOTERA:** Vatten kan samlas i maskinhuvudet, torka av synliga delar med en ren, torr trasa.

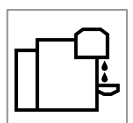

## AVKALKNING

Att avkalka din maskin kommer att säkerställa att den fungerar korrekt under hela dess livstid och kommer att göra din kaffeupplevelse lika fantastisk som den första dagen. Din maskin kommer att indikera när avkalkning behövs genom att blinka orange 3 gånger innan den blir stadigt vit.



**i** Avkalkningsproceduren tar ~20 minuter och kan inte avbrytas.

**NOTERA:** Läs igenom avkalkningsinstruktionerna noga innan du börjar.

### Du kommer att behöva:

- Ett avkalkningskit, tillgängligt på [www.nespresso.com](http://www.nespresso.com).
- En tom behållare (på 1 L).

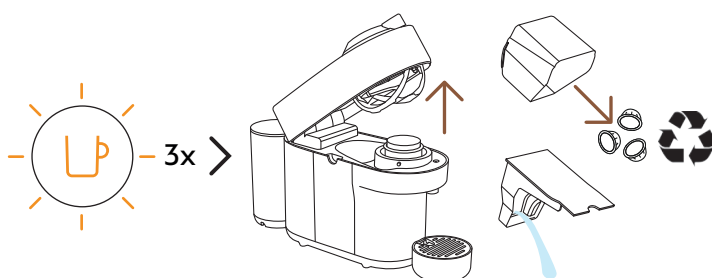

- 1** Med knappen blinkande orange 3 gånger: Lås upp och öppna maskinhuvudet och låt den använda kapseln lösas ut. Töm kapselbehållaren och droppbrickan och placera tillbaka dem på maskinen. Glöm inte att återvinna dina **Nespresso**-kapslar.\*

\* DETTA ÄR **NESPRESSO**. DETTA ÄR ÅTERVINNINGSBART. För mer information om återvinning av dina **Nespresso** kaffekapslar, besök [www.nespresso.com](http://www.nespresso.com)

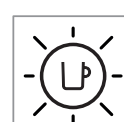
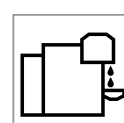
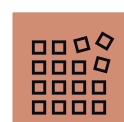
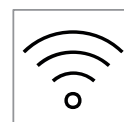

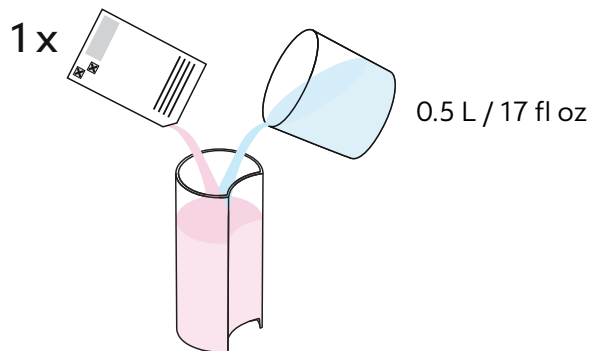

- 2** Fyll vattentanken med 0,5 L vatten och tillsätt 1 enhet av **Nespresso** avkalkningsvätska.

**WARNING:** Observera att avkalkningslösningen kan vara skadlig. Undvik kontakt med ögon, hud och ytor.

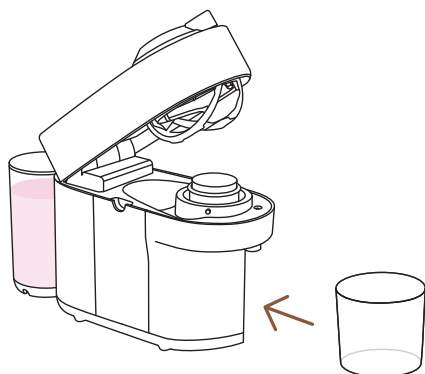

- 3** Ta bort kopphållaren och placera en tom behållare (på minst 1 L) under kaffeutloppet.

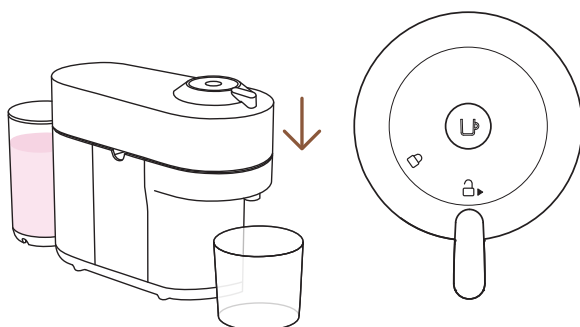

- 4** Med maskinen på, stäng maskinhuvudet och låt spaken vara olåst.

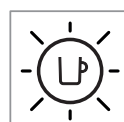
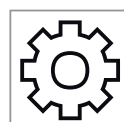
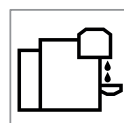
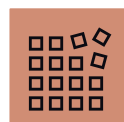
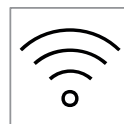

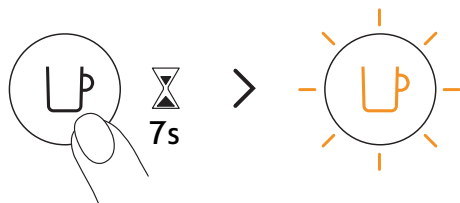

- 5** Håll ned knappen i minst 7 sekunder eller tills du ser att ljuset stängs av. Knappen kommer att börja blinka orange snabbt.

**WARNING:** Du har nu 45 sekunder på dig att gå in i avkalkningsläget, annars kommer maskinen gå tillbaka till bryggläget.

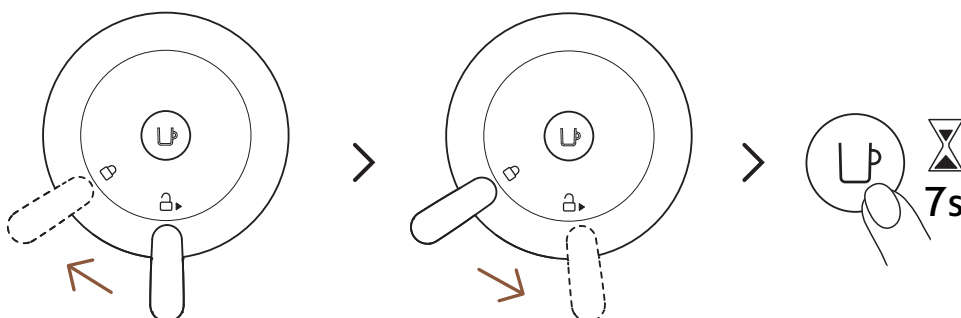

- 6** Lås maskinhuvudet genom att vrida spaken till vänster tills låssymbolen syns och lås sedan upp spaken genom att vrida till höger till olåst position. Tryck sedan och håll ned knappen igen i cirka 7 sekunder eller tills lampan stängs av. Knappen börjar blinka orange snabbt.

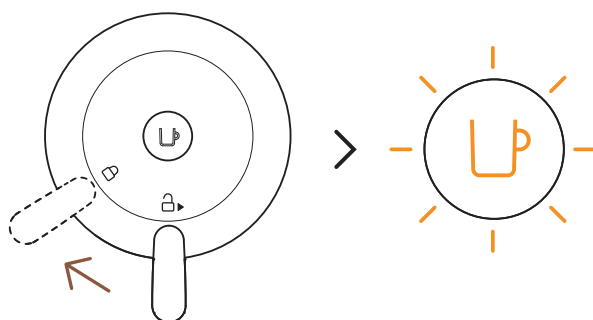

- 7** För att komma in i avkalkningsläget, lås maskinen genom att vrida spaken till vänster mot låst position. Lamporna ska fortfarande blinka orange snabbt. Detta indikerar att du har gått in i avkalkningsläget.

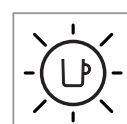
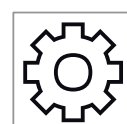
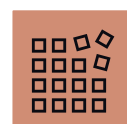
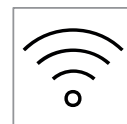

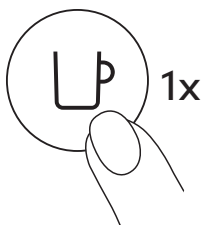

- 8** Tryck på kaffeknappen för att starta avkalkningsprocessen. Lampan kommer blinka orange under hela processen.
- i** Maskinen kommer att stanna automatiskt när den första fasen av avkalkningen är klar.

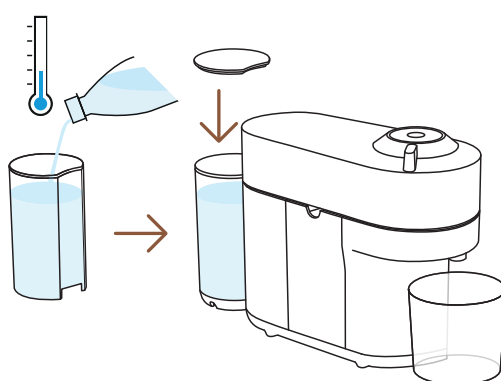

- 9** När avkalkningsprocessen är klar är det dags att skölja maskinen. Skölj vattentanken och droppbrickan ordentligt. Fyll vattentanken med färskt dricksvatten och sätt tillbaka den på plats. Töm behållaren och placera tillbaka den under kaffeutloppet.

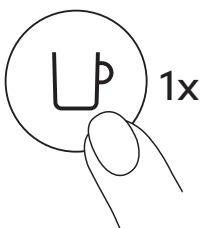

- 10** Tryck på knappen för att skölja maskinen. När knappen slutar blinka snabbt och blir stadigt, är avkalkningsproceduren klar.
- i** Maskinen stannar automatiskt när proceduren är klar.

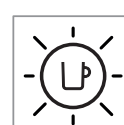
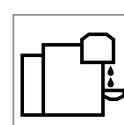
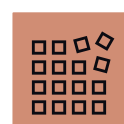
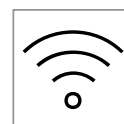

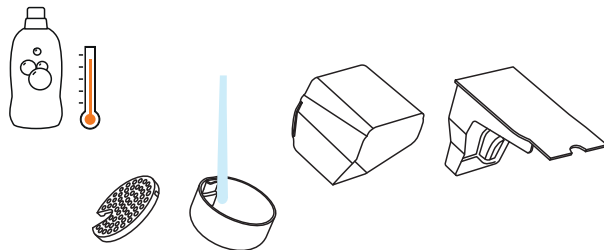

- 11** Tvätta kapselbehållaren, koppållaren och droppbrickan med varmt vatten och ett mildt, luktfritt rengöringsmedel.

**WARNING:** Använd inte något starkt eller abrasivt rengöringsmedel eller lösningsmedel. Sätt inte in maskinen i diskmaskinen. Doppa aldrig apparaten eller delar av den i vatten.

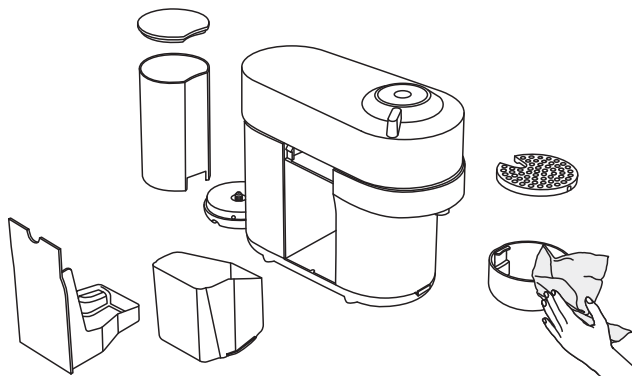

- 12** Torka maskinen med en ren och fräsch handduk. Låt maskinen torka i 10 minuter innan du använder den.

**NOTERA:** Vatten kan samlas inne i maskinhuvudet under rengöring. Om detta händer, torka synliga delar med en ren torr trasa.

**NOTERA:** Maskinen kan endast gå in i avkalkningsläge efter minst 30 kaffekapslar har blivit bryggda.

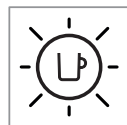
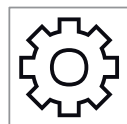
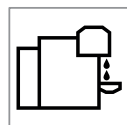
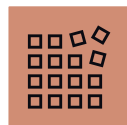
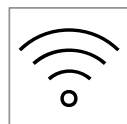

## TÖMNING AV SYSTEMET

Att tömma systemet är en process som kan göras före en period av icke-användning, för frostskydd eller innan maskinen skickas för reparation.

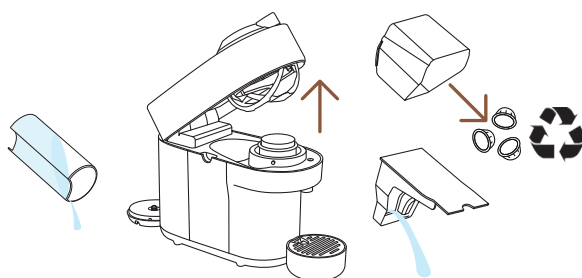

- 1** Töm vattentanken, öppna maskinhuvudet och låt den använda kapseln kastas ut. Töm behållaren för använda kapslar och droppbrickan. Glöm inte att återvinna dina **Nespresso**-kapslar.\*

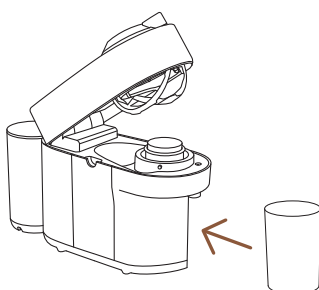

- 2** Placera tillbaka dem på maskinen, ta bort kopphållaren och placera en tom behållare (0,5 L) under kaffeutloppet.

\* DETTA ÄR **NESPRESSO**. DETTA ÄR ÅTERVINNINGSBART. För mer information om återvinning av dina **Nespresso** kaffekapslar, besök [www.nespresso.com](http://www.nespresso.com)

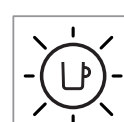
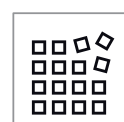
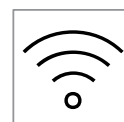

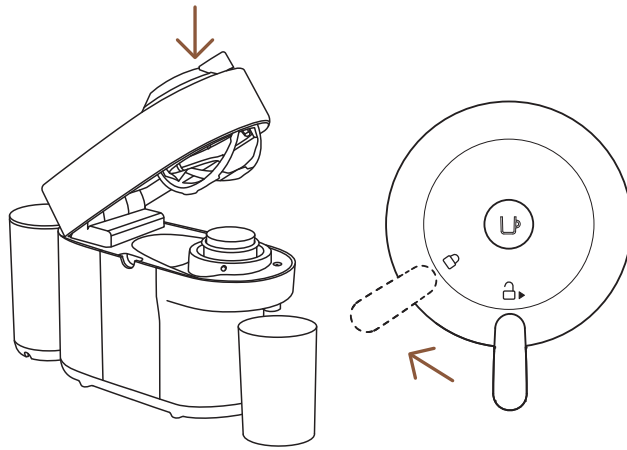

- 3** Med maskinen inkopplad och på, öppna och stäng maskinhuvudet och vrid spaken mot låst position.

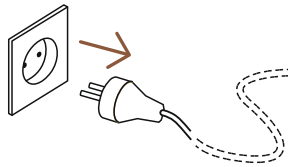

- 4** Koppla ur maskinen

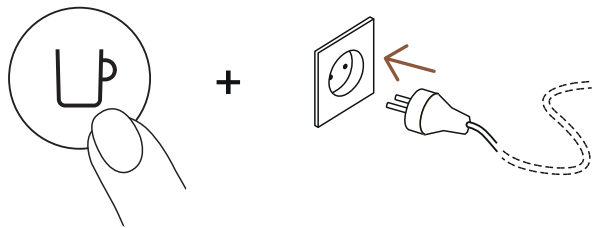

- 5** Tryck och håll ned knappen när du kopplar i kontakten

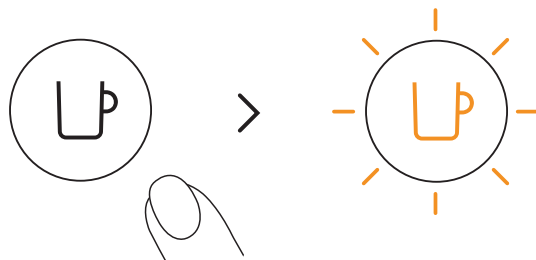

- 6** Släpp knappen. En orange lampa kommer att börja blinka och tömningsprocessen kommer att börja.

- i** Det tar ungefär 30 sekunder för maskinen att slutföra tömningsprocessen. Maskinen stängs automatiskt av när den är tom.

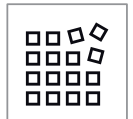

## ÅTERSTÄLL TILL FABRIKSINSTÄLLNINGAR

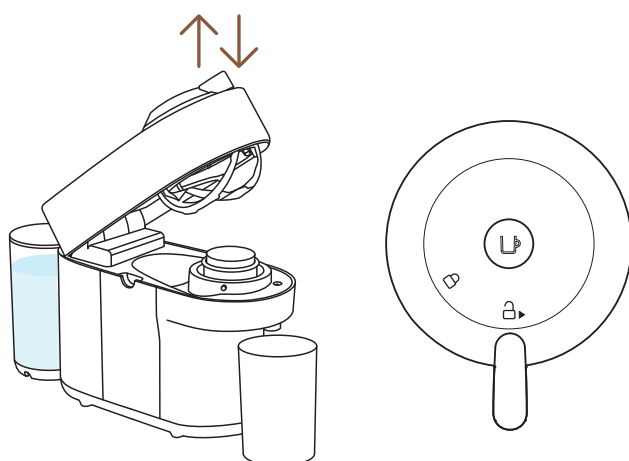

- 1 Med maskinen inkopplad, öppna och stäng maskinhuvudet innan du lämnar spaken i **upplåst** position.

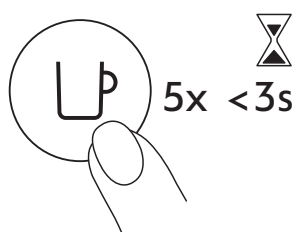

- 2 Tryck på knappen 5 gånger inom 3 sekunder. Maskinen är nu programmerad med fabriksinställningarna.

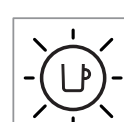
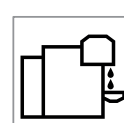
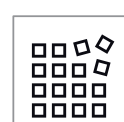
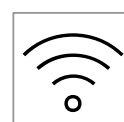

## SAMMANFATTNING BLINKNINGAR

Söker du mer information om blinkningar på Vertuo Pop?  
Vänligen titta på följande video.

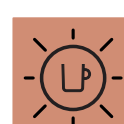
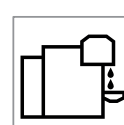
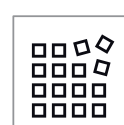
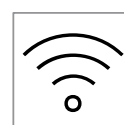

## FELSÖKNING

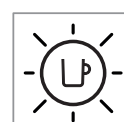
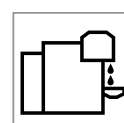
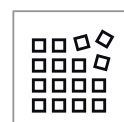
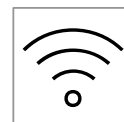

### Inget ljus runt knappen

- Maskinen har stängts AV automatiskt; tryck på knappen eller "LÅS UPP" maskinen.
- Kontrollera elnätet, kontakten, spänningen och säkringen.

### Inget kaffe, inget vatten

- Kontrollera att vattentanken är fylld.
- Kontrollera att en ny kapsel är isatt korrekt, att spaken är ordentligt låst och tryck på knappen för att starta.
- Avkalka om nödvändigt.
- Öppna maskinhuvudet och låt kapseln matas ur. Utför sedan rengöring enligt rengöringsavsnittet.

### Kaffet är inte varmt nog

- Förvärm koppen med varmt dricksvatten från kranen.
- Avkalka om nödvändigt.

### Läckage eller ovanligt kaffeflöde

- Kontrollera att vattentanken är korrekt placerad.
- Avkalka om nödvändigt.

### Maskinen sätter sig i "AV-läge"

- För att spara energi kommer maskinen stänga av sig efter 2 minuter utan användning.
- Maskinen kan stängas "AV" manuellt när som helst (när den inte används) genom att trycka och hålla ned knappen i 3 sekunder.

### Kaffesump i koppen

- Utför rengöringsproceduren två gånger.
- Se avsnittet om "Rengöring"

### Maskinen startar inte och har stadigt ljus på. Om ljuset blinkar, se nästa punkter:

- Kontrollera att spaken är låst ordentligt.
- Om du vill brygga en Kaffe eller Espresso, kontrollera att en ny kapsel är isatt korrekt, att spaken är låst ordentligt och tryck på knappen för att starta.
- Om du rengör, avkalkar eller tömmer systemet, kontrollera att ingen kapsel sitter i, stäng sedan och lås maskinen och tryck på knappen för att starta någon av dessa funktioner.

**Maskinen startar inte och ljuset blinkar växelvis: 1 blinkning och 1 paus.**

**Ljuset blinkar under tiden som maskinen körs.**

**Maskinen startar inte och ljuset blinkar växelvis: 1 blinkning och 1 paus.**

**Ljuset blinkar växelvis: 2 blinkningar och 1 paus kontinuerligt. Maskinen körs inte.**

- Fyll vattentanken och tryck på knappen för att starta.
- Kontrollera att spaken är låst ordentligt.
- Om kaffet rinner normalt indikerar detta att maskinen fungerar som den ska.
- Om det bara rinner vatten kör maskinen en användarbegäran för antingen rengöring, avkalkning eller tömning av systemet. Se motsvarande avsnitt.
- Sätt maskinen på "AV-läge" genom att trycka på knappen i 3 sekunder och tryck sedan på den igen för att slå på maskinen. Vänta nu cirka 20 minuter för att låta maskinen svalna efter omfattande användning.
- Det kommer att ta lite tid innan kaffeströmmen kommer ut (på grund av streckkodsläsning och förvätning av kaffet).
- Kontrollera att en ny kapsel är isatt korrekt, att spaken är ordentligt låst och tryck på knappen för att starta.
- Fyll vattentanken och tryck på knappen för att starta.
- Sätt maskinen på "AV-läge" genom att trycka på knappen i 3 sekunder och tryck sedan på den igen för att slå på maskinen. Vänta nu cirka 20 minuter för att låta maskinen svalna efter omfattande användning.
- Under vanlig Kaffe/Espresso-förberedelse:
  - 1) Lås upp spaken och öppna maskinhuvudet och kontrollera att en ny oskadad kapsel är isatt korrekt.
  - 2) Kontrollera att spaken är i "LÅST" position
  - 3) Kontrollera att vattentanken är fylld.
- Under Avkalkning, Tömning och Rengöring
  - 1) Kontrollera att kapseln har matats ut.
  - 2) Kontrollera att spaken är i "LÅST" position
- Under Volymprogrammering
  - 1) Kontrollera om en kapsel har isatts korrekt.
  - 2) Se motsvarande avsnitt.

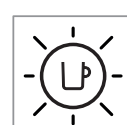
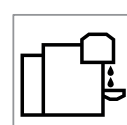
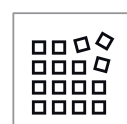
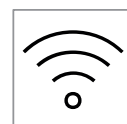

**Ljust blinkar växelvis 3 gånger och är sedan stadigt på.**

- Om problemet kvarstår:
  - 1) Lås upp spaken och öppna maskinhuvudet.
  - 2) Ersätt kapseln (om nödvändigt).
  - 3) Koppla ut sladden från uttaget och anslut maskinen till uttaget efter 10 sekunder.
  - 4) Stäng maskinhuvudet och tryck på knappen för att sätta PÅ och tryck igen för att börja brygga. Om problemet kvarstår, kontakta **Nespresso**.

Om problemet kvarstår, kontakta **Nespresso**.
- Avkalkning behövs: maskinen kan endast köras några få gånger när varning visas innan avkalkning blir nödvändig

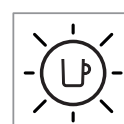
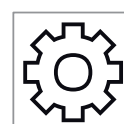
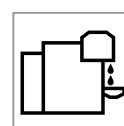
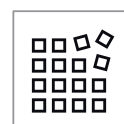
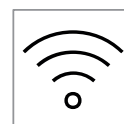

## SPECIFIKATIONER

<b>Ström</b>	<b>~220–240 V, 50–60 Hz, 1300–1500 W</b> <b>US, CA:</b> 120 V, 60 Hz, 1500 W <b>MX:</b> 127 V~, 60 Hz, 1380 W
<b>Frekvens</b>	2.402–2.480 GHz
<b>RF utgångseffekt (EIRP)</b>	Bluetooth 4 dBm Max. e.i.r.p. och Wi-Fi <20 dMm max. e.i.r.p.
<b>Standby</b>	0.39 W/h
<b>Strömsparkläge</b>	Automatisk avstängning: 2 min
<b>Uppvärmningstid</b>	30 sekunder (maskinhuvudet stängt och låst)
<b>Rörlig kopphållare för stora recept</b>	Avtagbar enpositionsållare
<b>Kabellängd från enhetens försändelse</b>	75 cm / 30 in
<b>Dimensioner (BxDxH)</b>	13.6 x 42.6 x 25 cm / 5.3 x 16.7 x 9.8 in
<b>Vikt</b>	3.5 kg / 7.72 lbs
<b>Vattentankskapacitet</b>	0.6 l / 20 fl oz
<b>Kapselbehållarkapacitet</b>	8 espresso- eller 5 mug-kapslar

## MASKINKODER

<b>Nespresso</b>	<b>Breville</b>	<b>Delonghi</b>
GCV2, GDV2	BNV120, BNV150	ENV90
<b>Krups</b>	<b>Magimix</b>	
XN9201, XN9204, XN9205, XN9211	M800	



